

Main Product Characteristics

Channel	N-Channel	P-Channel
B_{VDSS}	30V	-30V
$R_{DS(ON)}$	30m Ω	65m Ω
I_D	4A	-3A

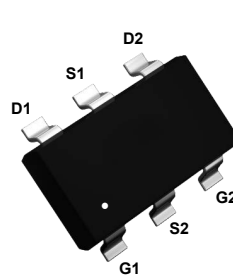

SOT-23-6L

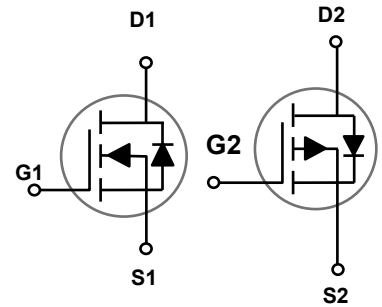

Schematic Diagram

Features and Benefits

- Advanced MOSFET process technology
- Ideal for high efficiency switched mode power supplies
- Low on-resistance with low gate charge
- Fast switching and reverse body recovery



Description

The SSF3714 utilizes the latest techniques to achieve high cell density and low on-resistance. These features make this device extremely efficient and reliable for use in high efficiency switch mode power supply and a wide variety of other applications.

Absolute Maximum Ratings ($T_J=25^{\circ}\text{C}$ unless otherwise specified)

Parameter	Symbol	Rating		Unit
Drain-Source Voltage	V_{DS}	30	-30	V
Gate-Source Voltage	V_{GS}	± 20	± 20	V
Drain Current – Continuous ($T_C=25^{\circ}\text{C}$)	I_D	4	-3	A
Drain Current – Continuous ($T_C=70^{\circ}\text{C}$)		2.5	-1.8	A
Drain Current – Pulsed ¹	I_{DM}	16	-12	A
Power Dissipation ($T_C=25^{\circ}\text{C}$)	P_D	2		W
Power Dissipation – Derate above 25 $^{\circ}\text{C}$		0.016		W/ $^{\circ}\text{C}$
Storage Temperature Range	T_{STG}	-55 to +150		$^{\circ}\text{C}$
Operating Junction Temperature Range	T_J	-55 to +150		$^{\circ}\text{C}$

Thermal Characteristics

Parameter	Symbol	Typ.	Max.	Unit
Thermal Resistance Junction to Ambient	$R_{\theta JA}$	-	100	$^{\circ}\text{C}/\text{W}$

N-Channel Electrical Characteristics (T_J=25°C unless otherwise specified)

Parameter	Symbol	Conditions	Min.	Typ.	Max.	Unit
Off Characteristics						
Drain-Source Breakdown Voltage	BV _{DSS}	V _{GS} =0V, I _D =250uA	30	-	-	V
Drain-Source Leakage Current	I _{DSS}	V _{DS} =30V, V _{GS} =0V, T _J =25°C	-	-	1	uA
		V _{DS} =24V, V _{GS} =0V, T _J =125°C	-	-	10	uA
Gate-Source Leakage Current	I _{GSS}	V _{GS} =±20V, V _{DS} =0V	-	-	±100	nA
On Characteristics						
Static Drain-Source On-Resistance	R _{DS(ON)}	V _{GS} =10V, I _D =4A	-	22	30	mΩ
		V _{GS} =4.5V, I _D =2A	-	35	46	
Gate Threshold Voltage	V _{GS(th)}	V _{GS} =V _{DS} , I _D =250uA	1.2	1.6	2.5	V
V _{GS(th)} Temperature Coefficient	ΔV _{GS(th)}		-	-4	-	mV/°C
Forward Transconductance	g _{fs}	V _{DS} =10V, I _D =3A	-	6.5	-	S
Dynamic and Switching Characteristics						
Total Gate Charge ^{2,3}	Q _g	V _{DS} =15V, V _{GS} =4.5V, I _D =6A	-	4.1	8	nC
Gate-Source Charge ^{2,3}	Q _{gs}		-	1	2	
Gate-Drain Charge ^{2,3}	Q _{gd}		-	2.1	4	
Turn-On Delay Time ^{2,3}	T _{d(on)}	V _{DD} =15V, V _{GS} =10V, R _θ =6Ω I _D =1A	-	2.8	5	nS
Rise Time ^{2,3}	T _r		-	7.2	14	
Turn-Off Delay Time ^{2,3}	T _{d(off)}		-	15.8	30	
Fall Time ^{2,3}	T _f		-	4.6	9	
Input Capacitance	C _{iss}	V _{DS} =25V, V _{GS} =0V, F=1MHz	-	345	500	pF
Output Capacitance	C _{oss}		-	55	80	
Reverse Transfer Capacitance	C _{rss}		-	32	45	
Gate Resistance	R _g	V _{GS} =0V, V _{DS} =0V, F=1MHz	-	3.2	6.4	Ω
Drain-Source Diode Characteristics and Maximum Ratings						
Parameter	Symbol	Conditions	Min.	Typ.	Max.	Unit
Continuous Source Current	I _S	V _G =V _D =0V, Force Current	-	-	4	A
Pulsed Source Current	I _{SM}		-	-	8	A
Diode Forward Voltage	V _{SD}	V _{GS} =0V, I _S =1A, T _J =25°C	-	-	1	V

Note:

1. Repetitive Rating: Pulsed width limited by maximum junction temperature.
2. The data tested by pulsed, pulse width ≤ 300uS, duty cycle ≤ 2%.
3. Essentially independent of operating temperature.

Typical Electrical and Thermal Characteristics

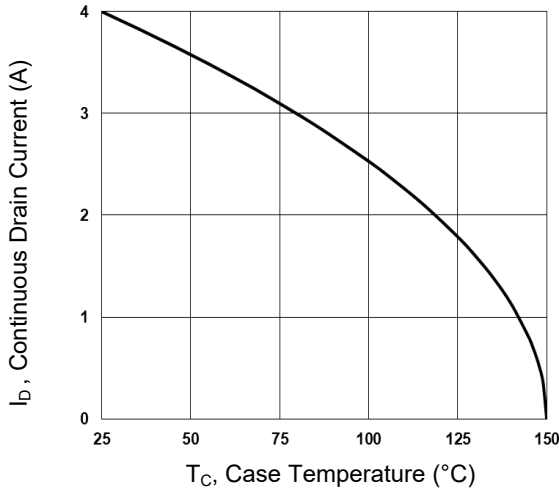

Figure 1. Continuous Drain Current vs. T_C

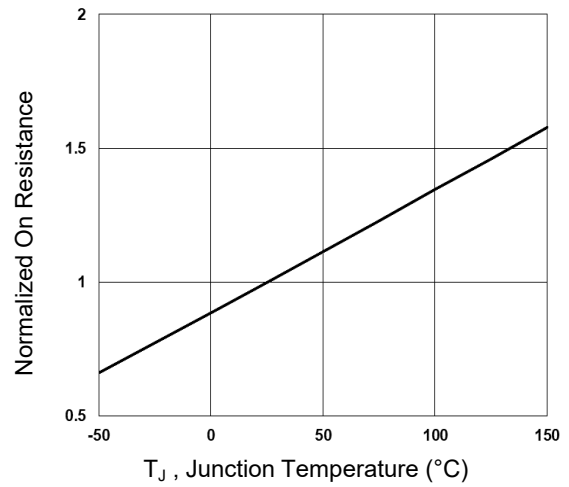

Figure 2. Normalized $R_{DS(on)}$ vs. T_J

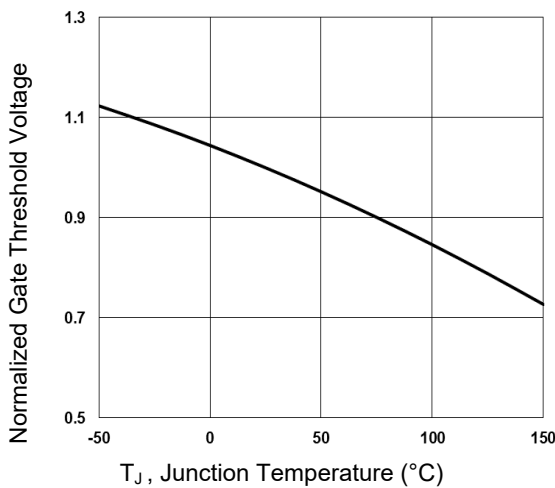

Figure 3. Normalized V_{th} vs. T_J

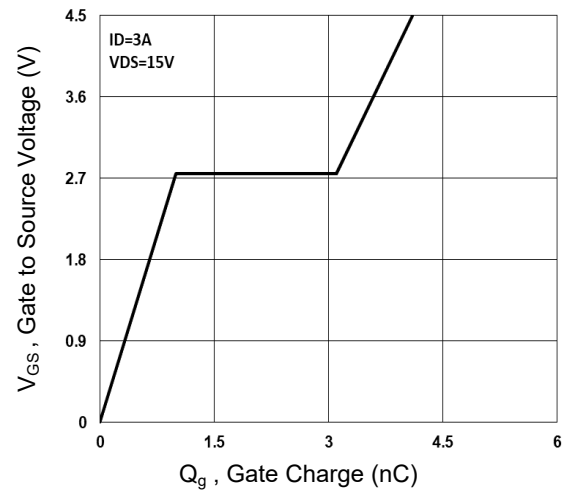

Figure 4. Gate Charge Waveform

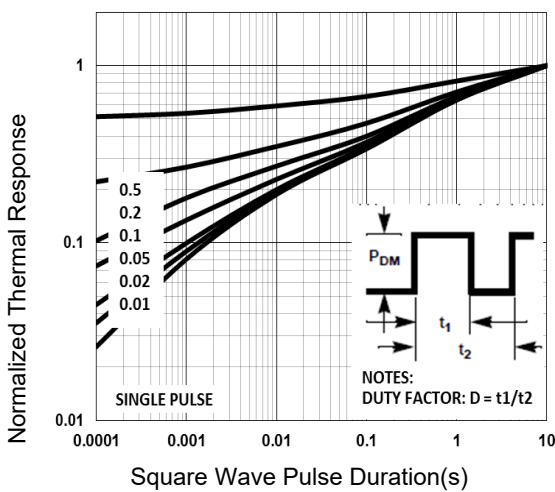

Figure 5. Normalized Transient Response

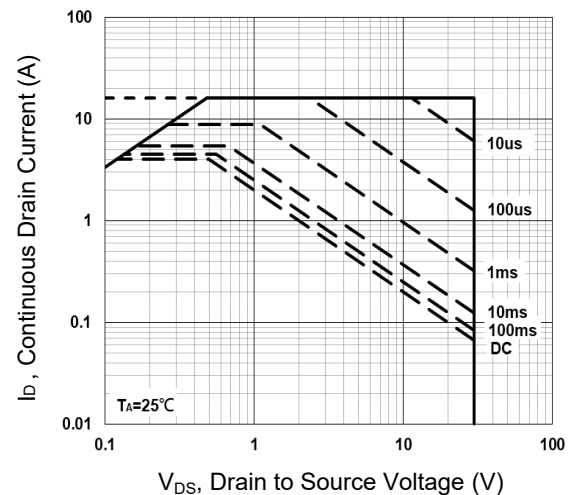

Figure 6. Maximum Safe Operation Area

P-Channel Electrical Characteristics (T_J=25°C unless otherwise specified)

Parameter	Symbol	Conditions	Min.	Typ.	Max.	Unit
Off Characteristics						
Drain-Source Breakdown Voltage	BV _{DSS}	V _{GS} =0V, I _b =-250uA	-30	-	-	V
BV _{DSS} Temperature Coefficient	ΔBV _{DSS} /ΔT _J	Reference to 25°C, I _b =-1mA	-	-0.03	-	V/°C
Drain-Source Leakage Current	I _{DSS}	V _{DS} =-30V, V _{GS} =0V, T _J =25°C	-	-	-1	uA
		V _{DS} =-24V, V _{GS} =0V, T _J =125°C	-	-	-10	uA
Gate-Source Leakage Current	I _{GSS}	V _{GS} =±20V, V _{DS} =0V	-	-	±100	nA
On Characteristics						
Static Drain-Source On-Resistance	R _{DS(ON)}	V _{GS} =-10V, I _b =-3A	-	45	65	mΩ
		V _{GS} =-4.5V, I _b =-2A	-	65	90	
Gate Threshold Voltage	V _{GS(th)}	V _{GS} =V _{DS} , I _D =-250uA	-1.2	-1.6	-2.2	V
V _{GS(th)} Temperature Coefficient	ΔV _{GS(th)}		-	4	-	mV/°C
Forward Transconductance	g _{fs}	V _{DS} =-10V, I _b =-3A	-	3.7	-	S
Dynamic and Switching Characteristics						
Total Gate Charge ^{2,3}	Q _g	V _{DS} =-30V, V _{GS} =-4.5V, I _b =-2A	-	5	8	nC
Gate-Source Charge ^{2,3}	Q _{gs}		-	1.4	3	
Gate-Drain Charge ^{2,3}	Q _{gd}		-	1.7	4	
Turn-On Delay Time ^{2,3}	T _{d(on)}	V _{DD} =-30V, V _{GS} =-10V, R _G =6Ω I _b =-1A	-	3.4	6	nS
Rise Time ^{2,3}	T _r		-	10.8	21	
Turn-Off Delay Time ^{2,3}	T _{d(off)}		-	26.9	51	
Fall Time ^{2,3}	T _f		-	6.9	13	
Input Capacitance	C _{iss}	V _{DS} =-30V, V _{GS} =0V, F=1MHz	-	420	810	pF
Output Capacitance	C _{oss}		-	50	80	
Reverse Transfer Capacitance	C _{rss}		-	35	60	
Drain-Source Diode Characteristics and Maximum Ratings						
Parameter	Symbol	Conditions	Min.	Typ.	Max.	Unit
Continuous Source Current	I _S	V _G =V _D =0V, Force Current	-	-	-3	A
Pulsed Source Current	I _{SM}		-	-	-6	A
Diode Forward Voltage	V _{SD}	V _{GS} =0V, I _S =1A, T _J =25°C	-	-	-1	V

Note:

1. Repetitive Rating: Pulsed width limited by maximum junction temperature.
2. The data tested by pulsed, pulse width ≤ 300uS, duty cycle ≤ 2%.
3. Essentially independent of operating temperature.

Typical Electrical and Thermal Characteristics

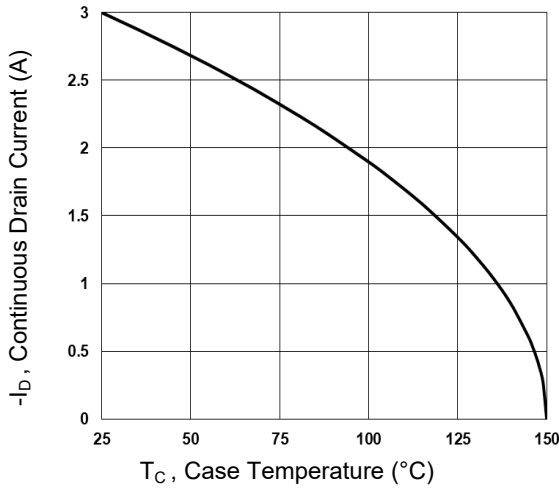

Figure 1. Continuous Drain Current vs. T_C

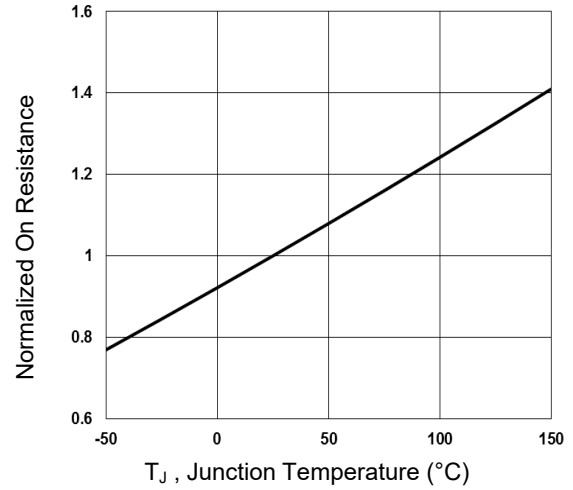

Figure 2. Normalized $R_{DS(on)}$ vs. T_J

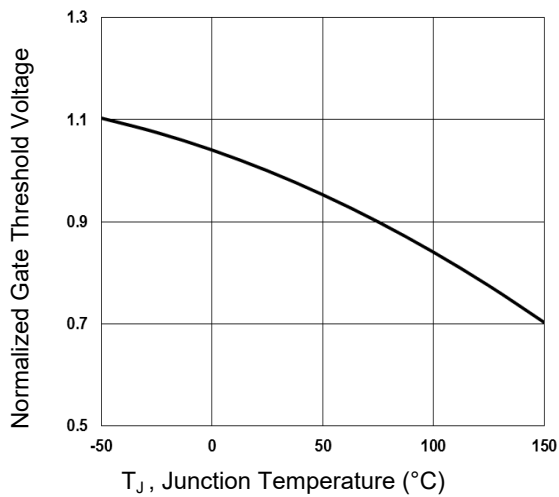

Figure 3. Normalized V_{th} vs. T_J

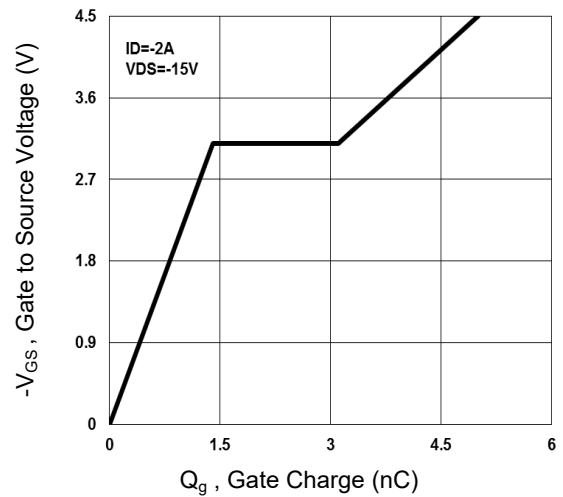

Figure 4. Gate Charge Waveform

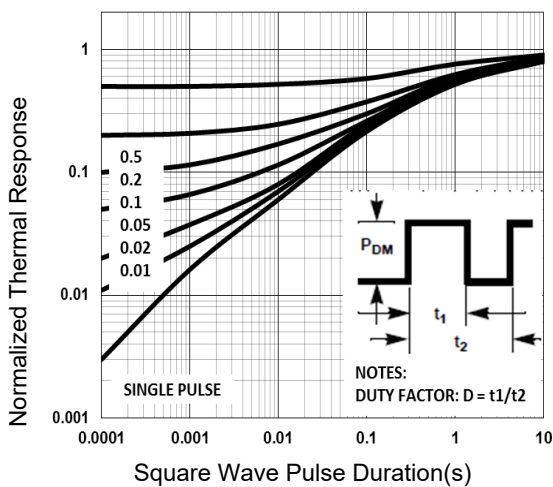

Figure 5. Normalized Transient Impedance

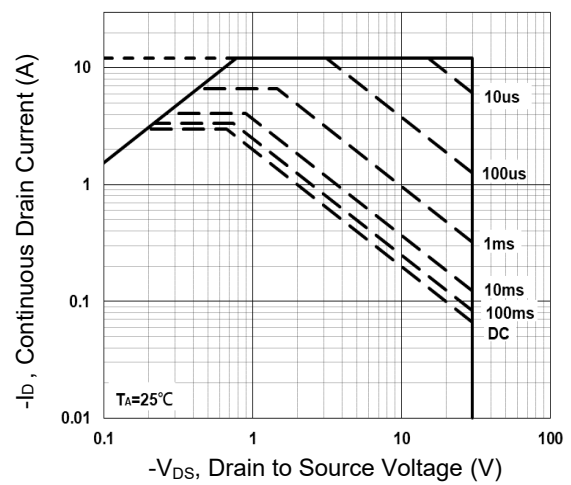
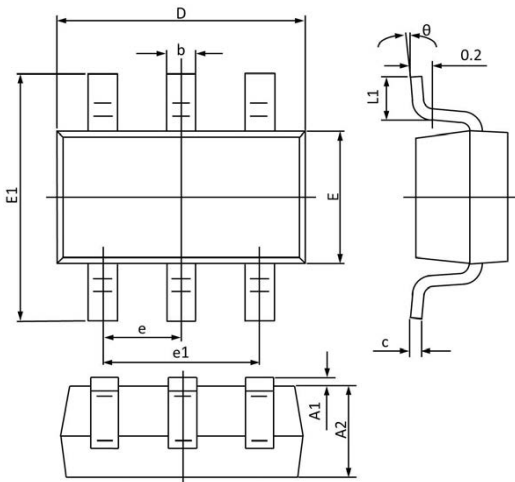

Figure 6. Maximum Safe Operation Area

Package Outline Dimensions (SOT-23-6L)



Symbol	Dimensions In Millimeters		Dimensions In Inches	
	Min	Max	Min	Max
A1	0.000	0.100	0.000	0.004
A2	1.000	1.200	0.040	0.047
b	0.300	0.500	0.012	0.019
c	0.047	0.207	0.002	0.008
D	2.800	3.000	0.110	0.118
E	1.500	1.800	0.059	0.070
E1	2.600	3.000	0.103	0.118
e	0.950 TYP		0.037 TYP	
e1	1.900 TYP		0.075 TYP	
L1	0.250	0.550	0.010	0.021
θ	0°	8°	0°	8°

Recommended Pad Layout

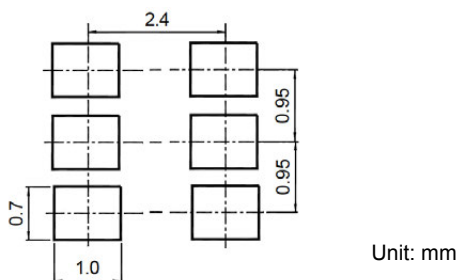

Order Information

Device	Package	Marking	Packaging	SPQ
SSF3714	SOT-23-6L	k	Tape & Reel	3,000 Pcs / Reel

For more information, please contact us at: inquiry@goodarksemi.com