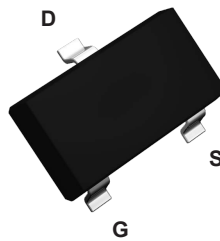
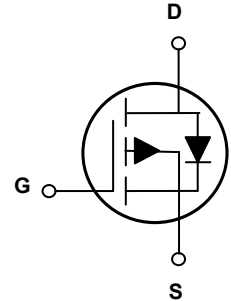


## Main Product Characteristics

$V_{(BR)DSS}$	-60V
$R_{DS(ON)}$	128m $\Omega$ (Typ.)
$I_D$	-2A



SOT-23



Schematic Diagram

## Features and Benefits

- Advanced MOSFET process technology
- Ideal for high efficiency switched mode power supplies
- Low on-resistance with low gate charge
- Fast switching and reverse body recovery



## Description

The GSFC0601 utilizes the latest techniques to achieve high cell density and low on-resistance. These features make this device extremely efficient and reliable for use in high efficiency switch mode power supplies and a wide variety of other applications.

## Absolute Maximum Ratings ( $T_c=25^\circ\text{C}$ unless otherwise specified)

Parameter	Symbol	Max.	Unit
Drain-Source Voltage	$V_{DS}$	-60	V
Gate-Source Voltage	$V_{GS}$	$\pm 20$	V
Drain Current-Continuous ( $T_c=25^\circ\text{C}$ )	$I_D$	-2	A
Drain Current-Continuous ( $T_c=100^\circ\text{C}$ )		-1.25	
Drain Current-Pulsed <sup>1</sup>	$I_{DM}$	-8	A
Power Dissipation ( $T_c=25^\circ\text{C}$ )	$P_D$	1.56	W
Power Dissipation-Derate above $25^\circ\text{C}$		0.012	
Thermal Resistance, Junction-to-Ambient	$R_{\theta JA}$	80	$^\circ\text{C/W}$
Operating Junction Temperature Range	$T_J$	-50 To +150	$^\circ\text{C}$
Storage Temperature Range	$T_{STG}$	-50 To +150	$^\circ\text{C}$

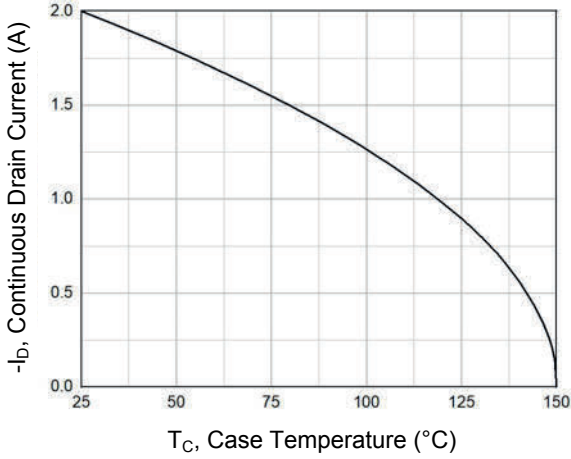
**Electrical Characteristics** ( $T_J=25^{\circ}\text{C}$  unless otherwise specified)

Parameter	Symbol	Conditions	Min.	Typ.	Max.	Unit
<b>On/Off Characteristics</b>						
Drain-Source Breakdown Voltage	$BV_{DSS}$	$V_{GS}=0V, I_D=-250\mu A$	-60	-	-	V
$BV_{DSS}$ Temperature Coefficient	$\Delta BV_{DSS}/\Delta T_J$	Reference to $25^{\circ}\text{C}$ , $I_D=-1mA$	-	-0.05	-	$V/^{\circ}\text{C}$
Drain-Source Leakage Current	$I_{DSS}$	$V_{DS}=-60V, V_{GS}=0V,$ $T_J=25^{\circ}\text{C}$	-	-	-1	$\mu A$
		$V_{DS}=-48V, V_{GS}=0V,$ $T_J=125^{\circ}\text{C}$	-	-	-10	$\mu A$
Gate-Source Leakage Current	$I_{GSS}$	$V_{GS}=\pm 20V, V_{DS}=0V$	-	-	$\pm 100$	$\mu A$
Static Drain-Source On-Resistance	$R_{DS(ON)}$	$V_{GS}=-10V, I_D=-1.8A$	-	128	189	m $\Omega$
		$V_{GS}=-4.5V, I_D=-1.2A$	-	160	239	
Gate Threshold Voltage	$V_{GS(th)}$	$V_{GS}=V_{DS}, I_D=-250\mu A$	-1.2	-1.9	-2.5	V
$V_{GS(th)}$ Temperature Coefficient	$\Delta V_{GS(th)}$		-	5	-	mV/ $^{\circ}\text{C}$
Forward Transconductance	$g_{fs}$	$V_{DS}=-10V, I_S=-2A$	-	3.5	-	S
<b>Dynamic and Switching Characteristics</b>						
Total Gate Charge <sup>2,3</sup>	$Q_g$	$V_{DS}=-30V, I_D=-2A,$ $V_{GS}=-10V$	-	8.2	12	nC
Gate-Source Charge <sup>2,3</sup>	$Q_{gs}$		-	1.8	3.6	
Gate-Drain Charge <sup>2,3</sup>	$Q_{gd}$		-	1.5	3	
Turn-On Delay Time <sup>2,3</sup>	$t_{d(on)}$	$V_{DD}=-30V, R_G=6\Omega,$ $V_{GS}=-10V, I_D=-1A$	-	5.2	10	nS
Rise Time <sup>2,3</sup>	$t_r$		-	19	36	
Turn-Off Delay Time <sup>2,3</sup>	$t_{d(off)}$		-	35	67	
Fall Time <sup>2,3</sup>	$t_f$		-	10.6	20	
Input Capacitance	$C_{iss}$	$V_{DS}=-30V, V_{GS}=0V,$ $F=1MHz$	-	425	615	pF
Output Capacitance	$C_{oss}$		-	35	50	
Reverse Transfer Capacitance	$C_{rss}$		-	20	30	
<b>Drain-Source Diode Characteristics and Maximum Ratings</b>						
Continuous Source Current	$I_S$	$V_G=V_D=0V,$ Force Current	-	-	-2	A
Pulsed Source Current	$I_{SM}$		-	-	-4	A
Diode Forward Voltage	$V_{SD}$	$V_{GS}=0V, I_S=-1A,$ $T_J=25^{\circ}\text{C}$	-	-0.81	-1	V

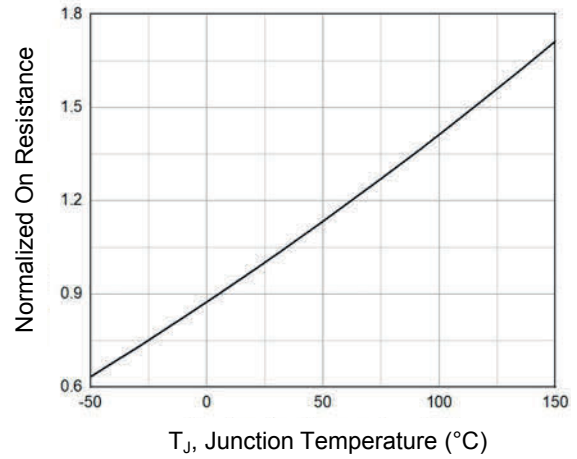
Note:

1. Repetitive rating: Pulsed width limited by maximum junction temperature.
2. The data tested by pulsed, pulse width  $\leq 300\mu s$ , duty cycle  $\leq 2\%$ .
3. Essentially independent of operating temperature.

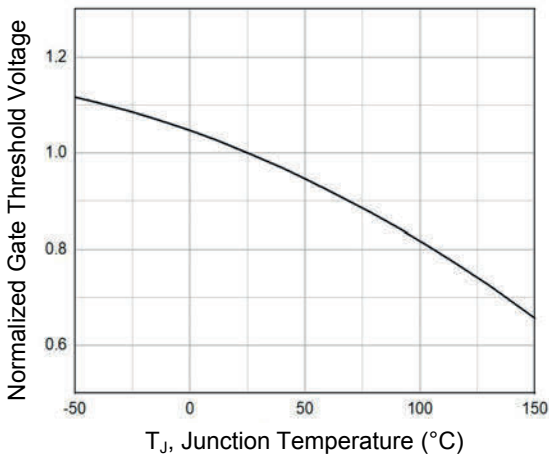
**Typical Electrical and Thermal Characteristic Curves**



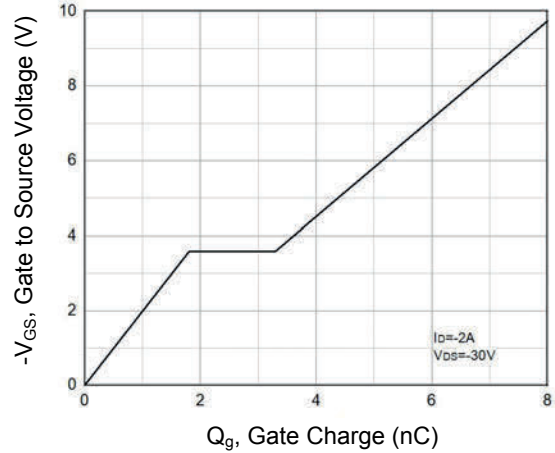
**Figure 1. Continuous Drain Current vs.  $T_C$**



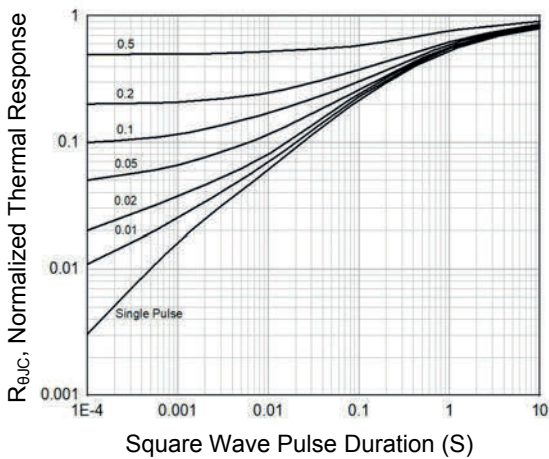
**Figure 2. Normalized  $R_{DS(ON)}$  vs.  $T_J$**



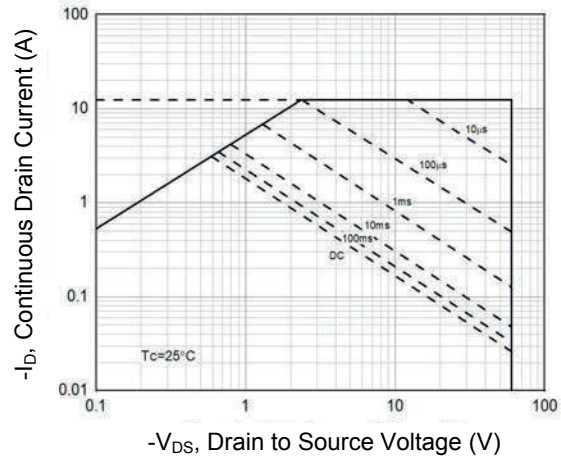
**Figure 3. Normalized  $V_{th}$  vs.  $T_J$**



**Figure 4. Gate Charge Waveform**

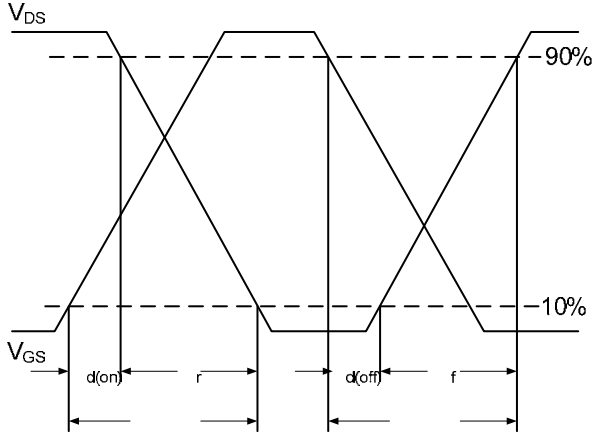


**Figure 5. Normalized Transient Impedance**

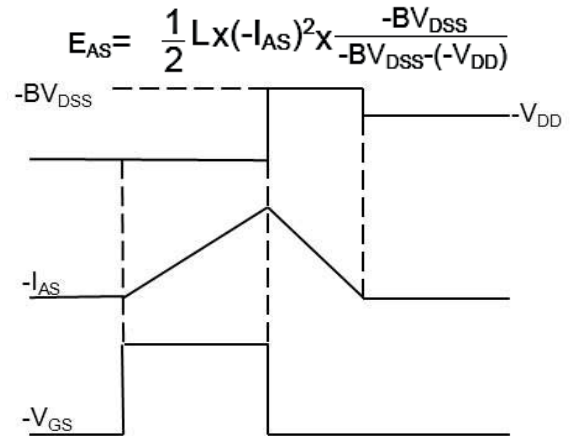


**Figure 6. Maximum Safe Operation Area**

**Typical Electrical and Thermal Characteristic Curves**

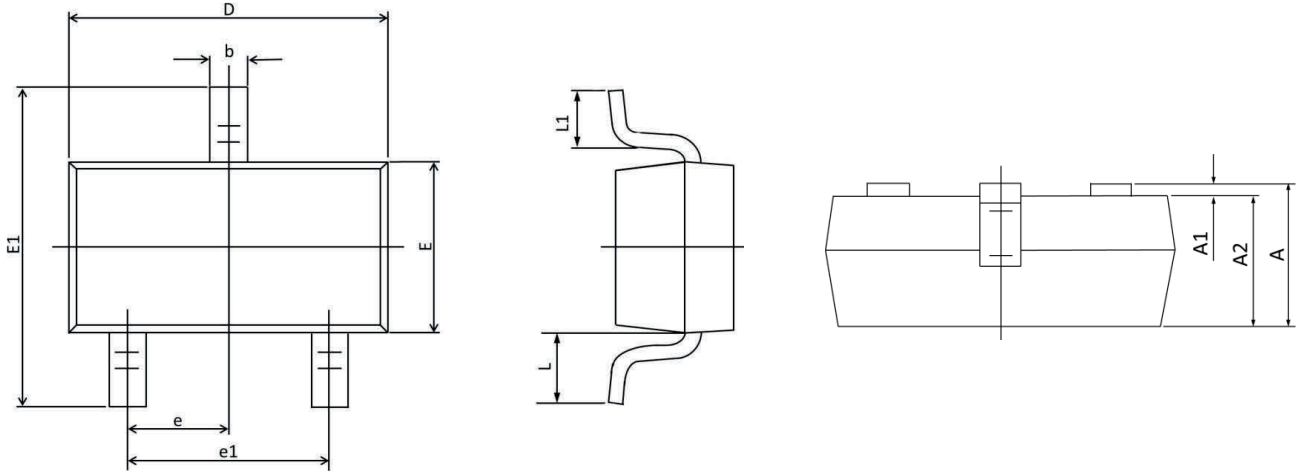


**Figure 7. Switching Time Waveform**



**Figure 8. EAS Waveform**

**Package Outline Dimensions (SOT-23)**



Symbol	Dimensions In Millimeters		Dimensions In Inches	
	Min	Max	Min	Max
A	0.900	1.200	0.035	0.047
A1	0.000	0.100	0.000	0.004
A2	0.900	1.150	0.035	0.045
b	0.300	0.500	0.012	0.020
D	2.800	3.040	0.110	0.120
E	1.200	1.400	0.047	0.055
E1	2.250	2.550	0.089	0.100
e	0.95 TYP.		0.037 TYP.	
e1	1.800	2.000	0.071	0.079
L	0.55 REF.		0.022 REF.	
L1	0.300	0.500	0.012	0.020

**Order Information**

Device	Package	Marking	Carrier	Quantity
GSFC0601	SOT-23	C0601	Tape & Reel	3,000 pcs / Reel

For more information, please contact us at: [inquiry@goodarksemi.com](mailto:inquiry@goodarksemi.com)