

Main Product Characteristics

$V_{(BR)DSS}$	100V
$R_{DS(ON)}$	13mΩ (Max.)
I_D	50A

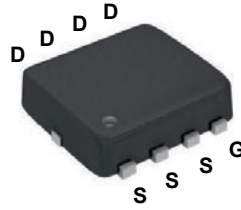

PPAK3x3

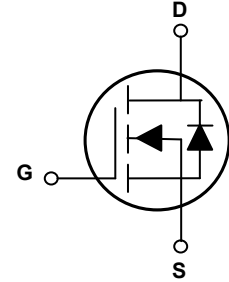

Schematic Diagram

Features and Benefits

- Advanced MOSFET process technology
- Ideal for high efficiency switched mode power supplies
- Low on-resistance with low gate charge
- Fast switching and reverse body recovery



Description

The GSFN13010 utilizes the latest techniques to achieve high cell density and low on-resistance. These features make this device extremely efficient and reliable for use in high efficiency switch mode power supplies and a wide variety of other applications.

Absolute Maximum Ratings ($T_C=25^{\circ}C$ unless otherwise specified)

Parameter	Symbol	Value	Unit
Drain-Source Voltage	V_{DS}	100	V
Gate-to-Source Voltage	V_{GS}	± 20	V
Continuous Drain Current, @ Steady-State ($T_C=25^{\circ}C$) ¹	I_D	50	A
Continuous Drain Current, @ Steady-State ($T_C=100^{\circ}C$)		35	A
Pulsed Drain Current ²	I_{DM}	200	A
Power Dissipation ($T_C=25^{\circ}C$)	P_D	45	W
Linear Derating Factor ($T_C=25^{\circ}C$)		0.36	W/ $^{\circ}C$
Single Pulse Avalanche Energy ³	E_{AS}	31	mJ
Junction-to-Case	$R_{\theta JC}$	2.78	$^{\circ}C/W$
Junction-to-Ambient (PCB Mounted, Steady-State) ⁴	$R_{\theta JA}$	62.0	$^{\circ}C/W$
Operating Junction and Storage Temperature Range	T_J/T_{STG}	-55 to +150	$^{\circ}C$

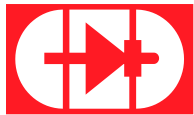
Electrical Characteristics ($T_C=25^\circ\text{C}$ unless otherwise specified)

Parameter	Symbol	Conditions	Min.	Typ.	Max.	Unit
On / Off Characteristics						
Drain-to-Source Breakdown Voltage	$V_{(BR)DSS}$	$V_{GS}=0V, I_D=250\mu A$	100	-	-	V
Drain-to-Source Leakage Current	I_{DSS}	$V_{DS}=100V, V_{GS}=0V$	-	-	1	μA
		$T_J=125^\circ C$	-	-	20	
Gate-to-Source Forward Leakage	I_{GSS}	$V_{GS}=20V$	-	-	100	nA
		$V_{GS}=-20V$	-	-	-100	
Static Drain-to-Source On-Resistance	$R_{DS(on)}$	$V_{GS}=10V, I_D=20A$	-	11	13	m Ω
		$V_{GS}=4.5V, I_D=10A$	-	15	20	
Gate Threshold Voltage	$V_{GS(th)}$	$V_{DS}=V_{GS}, I_D=250\mu A$	1.1	-	2.6	V
Dynamic and Switching Characteristics						
Input Capacitance	C_{iss}	$V_{GS}=0V, V_{DS}=50V$ $F=1MHz$	-	1716	-	μF
Output Capacitance	C_{oss}		-	171	-	
Reverse Transfer Capacitance	C_{rss}		-	4	-	
Total Gate Charge	Q_g	$I_D=20A, V_{DS}=50V,$ $V_{GS}=10V$	-	29	-	nC
Gate-to-Source Charge	Q_{gs}		-	7.1	-	
Gate-to-Drain ("Miller") Charge	Q_{gd}		-	7.0	-	
Turn-on Delay Time	$t_{d(on)}$	$V_{GS}=10V, V_{DS}=50V,$ $I_D=20A, R_{GEN}=3\Omega$	-	7.6	-	nS
Rise Time	t_r		-	28	-	
Turn-Off Delay Time	$t_{d(off)}$		-	32	-	
Fall Time	t_f		-	11	-	
Gate Resistance	R_g	$F=1MHz$	-	2.4	-	Ω
Source-Drain Ratings and Characteristics						
Continuous Source Current (Body Diode)	I_S	MOSFET symbol showing the integral reverse-p-n junction diode.	-	-	50	A
Pulsed Source Current (Body Diode)	I_{SM}		-	-	200	A
Diode Forward Voltage	V_{SD}	$I_S=20A, V_{GS}=0V$	-	1.0	1.3	V
Reverse Recovery Time	T_{rr}	$T_J=25^\circ C, I_F=20A,$ $di/dt=100A/\mu s$	-	42	-	nS
Reverse Recovery Charge	Q_{rr}		-	50	-	nC

Notes:

1. Pulse test: pulse width $\leq 300\mu s$, duty cycle $\leq 2\%$.
2. Repetitive rating; pulse width limited by max. junction temperature.
3. $L=0.1mH, V_{DD}=80V, I_{AS}=25A, R_G=25\Omega, T_J=25^\circ C$.
4. Device mounted on FR-4 PCB, 1 inch x 0.85 inch x 0.062 inch.

Typical Electrical and Thermal Characteristic Curves

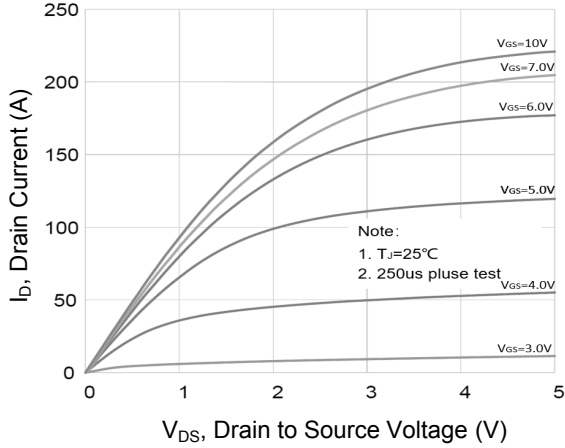

Figure 1. Output Characteristics

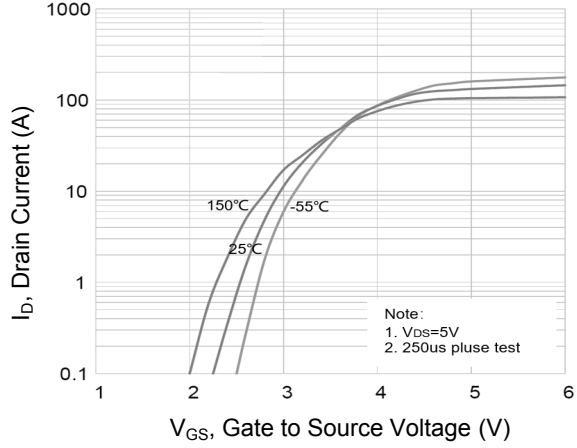

Figure 2. Transfer Characteristics

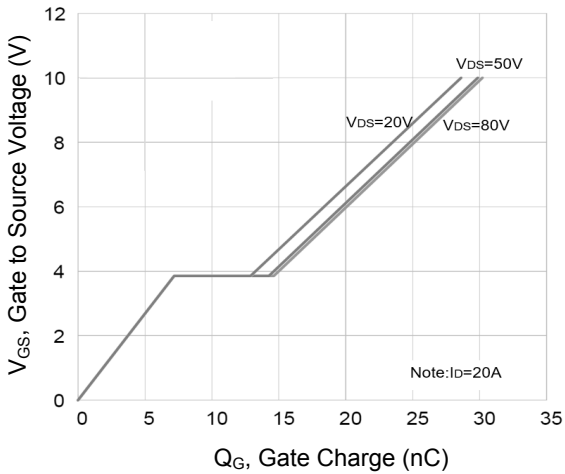

Figure 3. Gate Charge

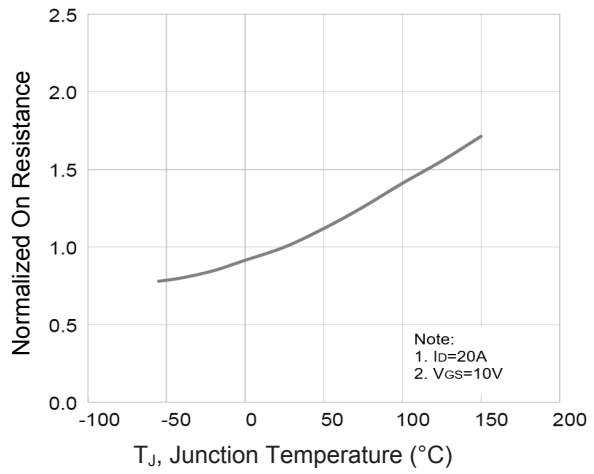

Figure 4. Normalized $R_{DS(ON)}$ vs. T_J

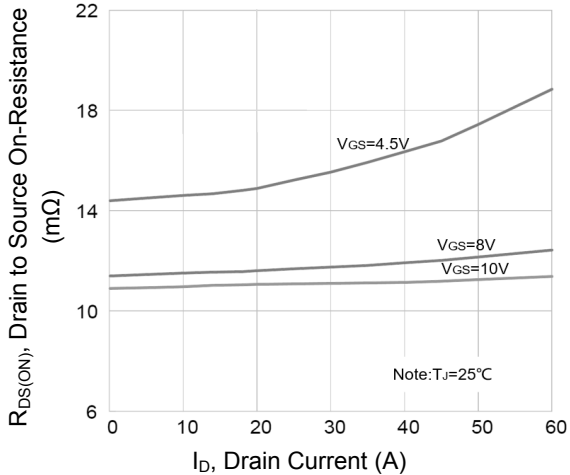

Figure 5. $R_{DS(ON)}$ vs. Drain Current

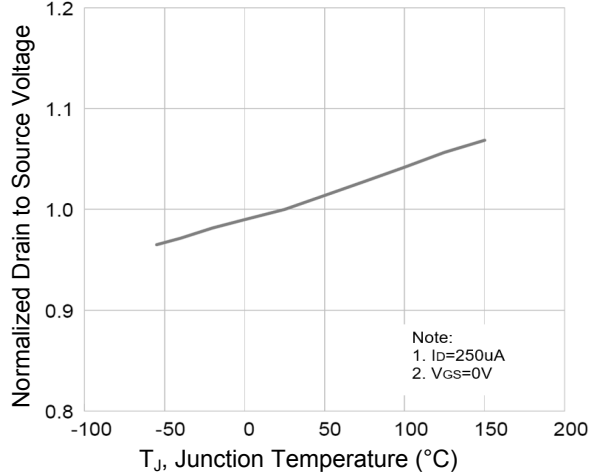

Figure 6. Normalized BV_{DSS} vs. T_J

Typical Electrical and Thermal Characteristic Curves

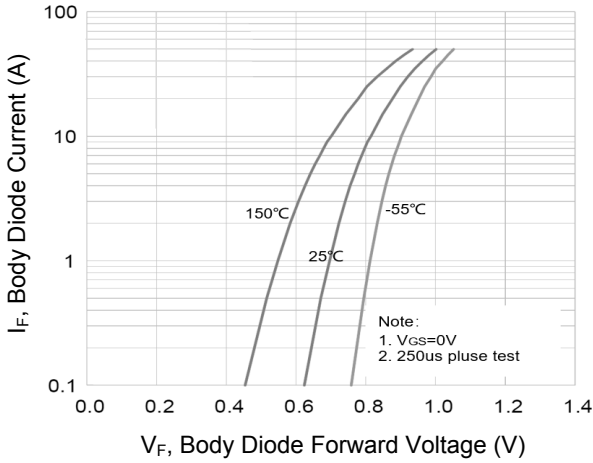

Figure 7. Body Diode Characteristics

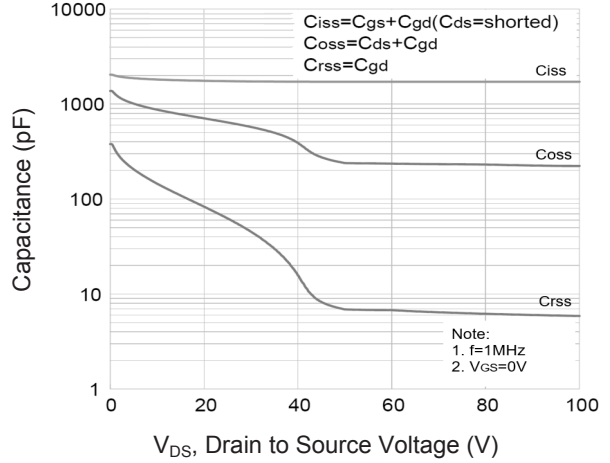

Figure 8. Capacitance Characteristics

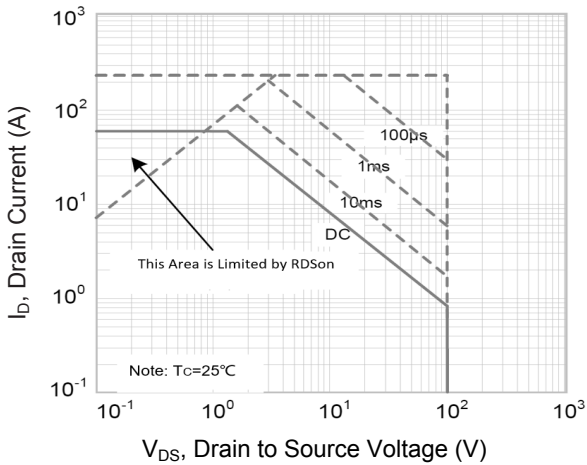
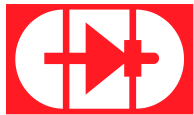
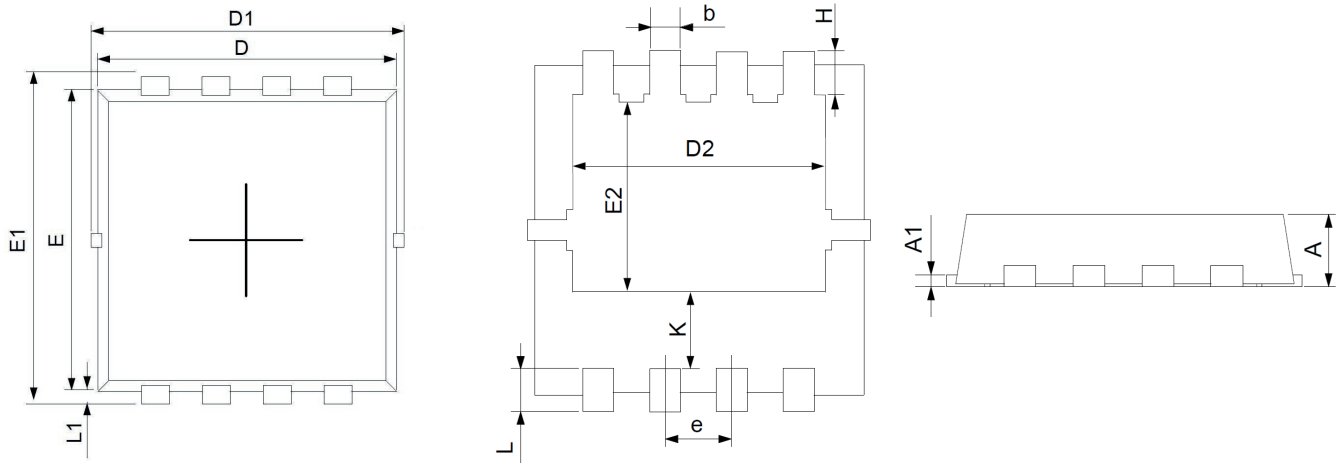

Figure 9. Safe Operation Area



Package Outline Dimensions (PPAK3x3)



Symbol	Dimensions In Millimeters		Dimensions In Inches	
	Min.	Max.	Min.	Max.
A	0.70	0.90	0.028	0.035
A1	0.14	0.20	0.006	0.008
D	3.05	3.25	0.120	0.128
E	2.90	3.10	0.114	0.122
D1	3.10	3.50	0.122	0.138
D2	2.35	2.50	0.093	0.098
E1	3.10	3.50	0.122	0.138
E2	1.64	1.84	0.065	0.072
b	0.25	0.35	0.010	0.014
K	0.59	0.79	0.023	0.031
e	0.55	0.75	0.022	0.030
L	0.25	0.55	0.010	0.022
L1	0.10	0.20	0.004	0.008
H	0.32	0.52	0.013	0.020

Order Information

Device	Package	Marking	Packaging	SPQ
GSFN13010	PPAK3x3	N13010	Tape & Reel	5,000pcs / Reel