

Main Product Characteristics

$V_{(BR)DSS}$	150V
$R_{DS(ON)}$	4.8m Ω (Typ.)
I_D	175A

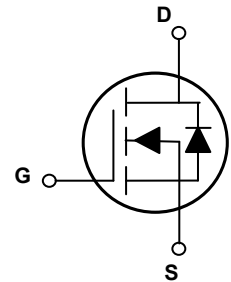

TO-247



Schematic Diagram

Features and Benefits

- Advanced MOSFET process technology
- Ideal for high efficiency switched mode power supplies
- Low on-resistance with low gate charge
- Fast switching and reverse body recovery



Description

The GSGA6R015 utilizes the latest techniques to achieve high cell density and low on-resistance. These features make this device extremely efficient and reliable for use in high efficiency switch mode power supplies and a wide variety of other applications.

Absolute Maximum Ratings (T_C=25°C unless otherwise specified)

Parameter	Symbol	Max.	Unit
Drain-Source Voltage	V _{DS}	150	V
Gate-Source Voltage	V _{GS}	±20	V
Drain Current-Continuous, at Steady-State, (T _C =25°C) ¹	I _D	175	A
Drain Current-Continuous, at Steady-State, (T _C =100°C)		124	
Drain Current-Pulsed ²	I _{DM}	690	A
Single Pulse Avalanche Energy ³	E _{AS}	803	mJ
Power Dissipation (T _A =25°C)	P _D	500	W
Linear Derating Factor (T _A =25°C)		3.33	
Junction-to-Ambient (PCB Mounted, Steady-State) ⁴	R _{θJA}	62	°C/W
Thermal Resistance, Junction-to-Case	R _{θJC}	0.3	°C/W
Operating Junction Temperature Range	T _J	-55 To +175	°C
Storage Temperature Range	T _{STG}	-55 To +175	°C

Electrical Characteristics ($T_A=25^\circ\text{C}$ unless otherwise specified)

Parameter	Symbol	Conditions	Min.	Typ.	Max.	Unit
On / Off Characteristics						
Drain-Source Breakdown Voltage	BV_{DSS}	$V_{GS}=0V, I_D=250\mu A$	150	-	-	V
Drain-Source Leakage Current	I_{DSS}	$V_{DS}=150V, V_{GS}=0V$	-	-	1	μA
		$T_J=125^\circ C$	-	-	50	μA
Gate-Source Leakage Current	I_{GSS}	$V_{GS}=\pm 20V$	-	-	± 100	nA
Static Drain-Source On-Resistance	$R_{DS(ON)}$	$V_{GS}=10V, I_D=100A$	-	4.8	6.0	m Ω
Gate Threshold Voltage	$V_{GS(th)}$	$V_{GS}=V_{DS}, I_D=250\mu A$	2.1	3	3.9	V
Dynamic and Switching Characteristics						
Total Gate Charge	Q_g	$V_{DS}=120V, I_D=100A, V_{GS}=10V$	-	81	-	nC
Gate-Source Charge	Q_{gs}		-	29	-	
Gate-Drain ("Miller") Charge	Q_{gd}		-	15	-	
Turn-On Delay Time	$t_{d(on)}$	$V_{DS}=75V, R_{GEN}=2.5\Omega, V_{GS}=10V, I_D=80A$	-	16.5	-	nS
Rise Time	t_r		-	106.3	-	
Turn-Off Delay Time	$t_{d(off)}$		-	60.6	-	
Fall Time	t_f		-	104.6	-	
Input Capacitance	C_{iss}	$V_{DS}=25V, V_{GS}=0V, F=1MHz$	-	5400	-	pF
Output Capacitance	C_{oss}		-	3300	-	
Reverse Transfer Capacitance	C_{rss}		-	80	-	
Gate Resistance	R_g	$F=1MHz$	-	4.3	-	Ω
Drain-Source Diode Characteristics and Maximum Ratings						
Continuous Source Current (Body Diode)	I_S	MOSFET symbol showing the integral reverse p-n junction diode.	-	-	175	A
Pulsed Source Current (Body Diode)	I_{SM}		-	-	690	A
Diode Forward Voltage	V_{SD}	$V_{GS}=0V, I_S=80A$	-	1	1.2	V
Reverse Recovery Time	t_{rr}	$T_J=25^\circ C, I_F=80A, di/dt=100A/\mu s$	-	110	-	nS
Reverse Recovery Charge	Q_{rr}		-	0.36	-	μC

Note:

1. Pulse test: pulse width $\leq 300\mu s$, duty cycle $\leq 2\%$.
2. Repetitive rating; pulse width limited by max. junction temperature.
3. $L=0.3mH, V_{DD}=50V, R_G=25\Omega, T_J=25^\circ C$.
4. Device mounted on FR-4 PCB, 1 inch x 0.85 inch x 0.062 inch.

Typical Electrical and Thermal Characteristic Curves

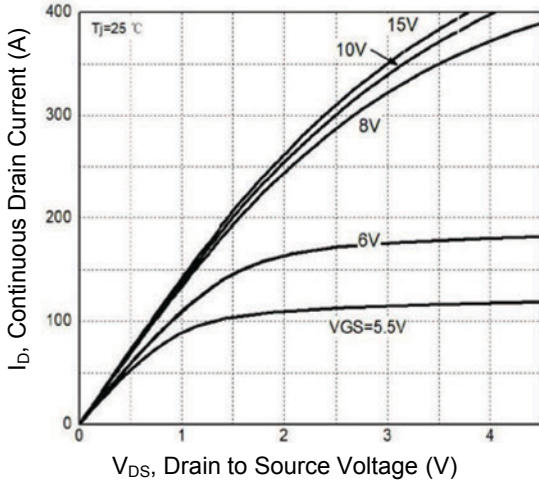

Figure 1. Typical Output Characteristics

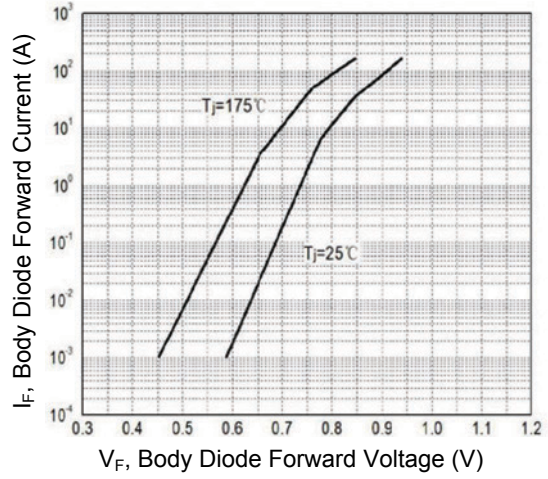

Figure 2. Body Diode Characteristics

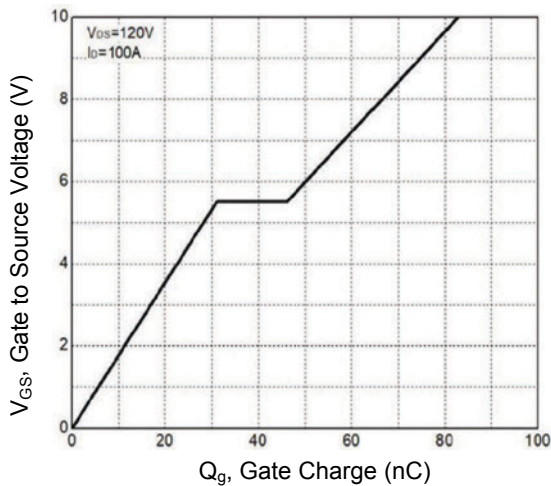

Figure 3. Gate Charge Characteristics

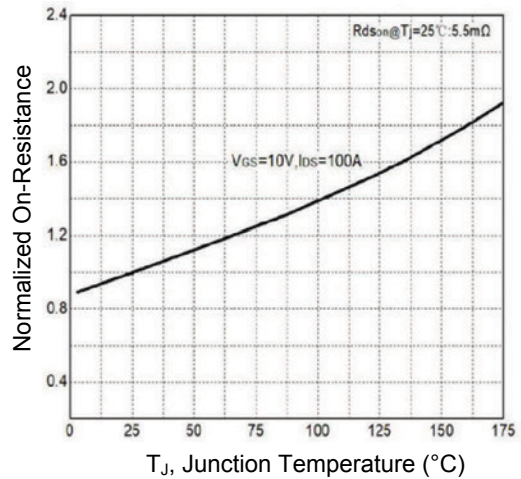

Figure 4. Normalized $R_{DS(ON)}$ vs. T_J

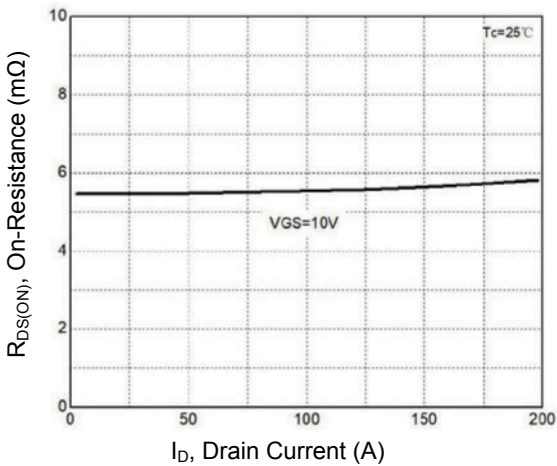

Figure 5. $R_{DS(ON)}$ vs. Drain Current

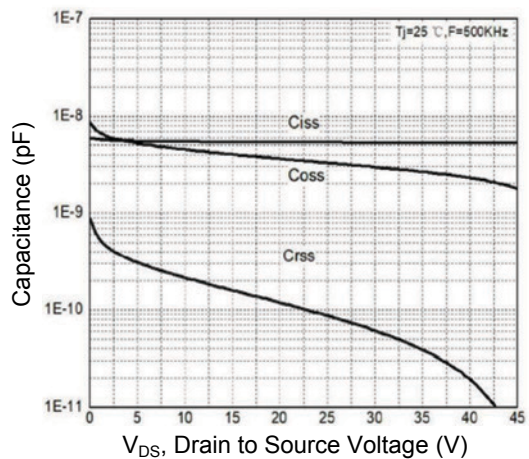

Figure 6. Typical Capacitance Characteristics

Typical Electrical and Thermal Characteristic Curves

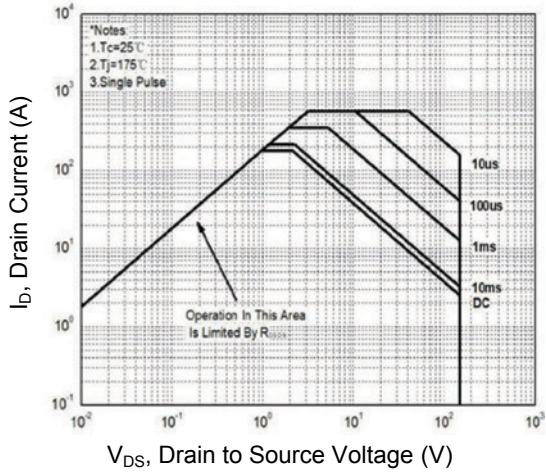

Figure 7. Safe Operation Area

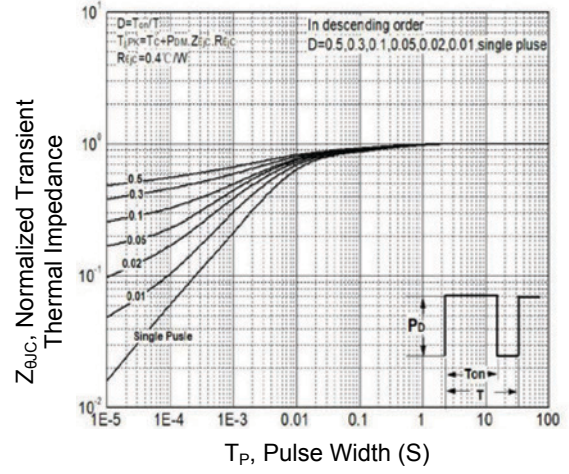
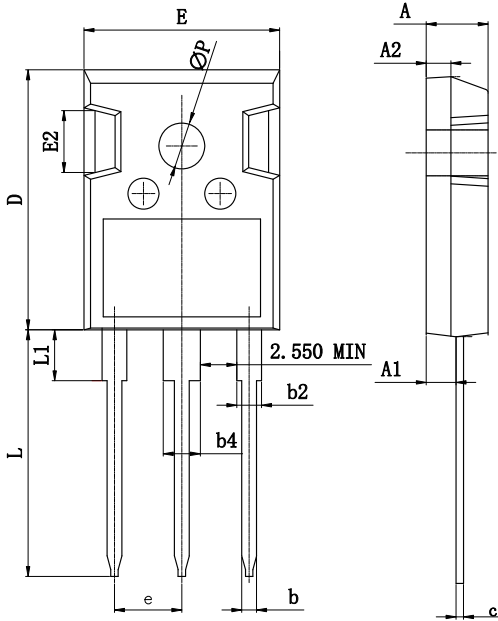

Figure 8. Thermal Transient Impedance

Package Outline Dimensions (TO-247)



Symbol	Dimensions In Millimeters		Dimensions In Inches	
	Min.	Max.	Min.	Max.
A	4.75	5.20	0.187	0.205
A1	2.21	2.65	0.087	0.104
A2	1.85	2.15	0.073	0.085
b	1.00	1.36	0.039	0.054
b2	1.80	2.25	0.071	0.089
b4	2.91	3.25	0.115	0.128
c	0.51	0.75	0.020	0.030
D	20.80	21.30	0.819	0.839
E	15.50	16.10	0.610	0.634
E2	4.40	5.20	0.173	0.205
e	5.44 BSC		0.214 BSC	
L	19.72	20.22	0.776	0.796
L1	-	4.30	-	0.169
P	3.40	3.80	0.134	0.150

Order Information

Device	Package	Marking	Carrier	Quantity
GSGA6R015	TO-247	A6R015	Tube	30pcs / Tube

For more information, please contact us at: inquiry@goodarksemi.com