

Main Product Characteristics

$V_{(BR)DSS}$	60V
$R_{DS(ON)}$	30m Ω
I_D	10A

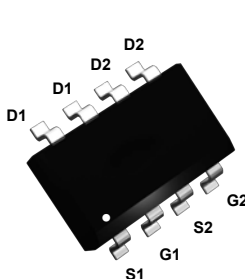

SOP-8

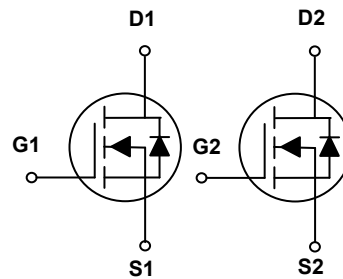

Schematic Diagram

Features and Benefits

- Advanced MOSFET process technology
- Ideal for high efficiency switched mode power supplies
- Low on-resistance with low gate charge
- Fast switching and reverse body recovery



Description

The GSFQ6808 utilizes the latest techniques to achieve high cell density and low on-resistance. These features make this device extremely efficient and reliable for use in high efficiency switch mode power supply and a wide variety of other applications.

Absolute Maximum Ratings ($T_C=25^{\circ}C$ unless otherwise specified)

Parameter	Symbol	Max.	Unit
Drain-Source Voltage	V_{DS}	60	V
Gate-Source Voltage	V_{GS}	± 20	V
Drain Current-Continuous ($T_C=25^{\circ}C$)	I_D	10	A
Drain Current-Continuous ($T_C=100^{\circ}C$)		6.3	
Drain Current-Continuous ($T_A=25^{\circ}C$)		5	
Drain Current-Continuous ($T_A=70^{\circ}C$)		4	
Drain Current-Pulsed ¹	I_{DM}	40	A
Single Pulse Avalanche Energy ²	E_{AS}	26.5	mJ
Single Pulse Avalanche Current ²	I_{AS}	23	A
Power Dissipation ($T_C=25^{\circ}C$)	P_D	3.6	W
Power Dissipation ($T_A=25^{\circ}C$)		1.47	W/ $^{\circ}C$
Thermal Resistance, Junction-to-Ambient ³	$R_{\theta JA}$	85	$^{\circ}C/W$
Thermal Resistance, Junction-to-Case ³	$R_{\theta JC}$	35	$^{\circ}C/W$
Operating Junction Temperature Range	T_J	-55 To +150	$^{\circ}C$
Storage Temperature Range	T_{STG}	-55 To +150	$^{\circ}C$

Electrical Characteristics ($T_J=25^\circ\text{C}$ unless otherwise specified)

Parameter	Symbol	Conditions	Min.	Typ.	Max.	Unit
On/Off Characteristics						
Drain-Source Breakdown Voltage	BV_{DSS}	$V_{GS}=0V, I_D=250\mu A$	60	-	-	V
BV_{DSS} Temperature Coefficient	$\Delta BV_{DSS}/\Delta T_J$	Reference to 25°C , $I_D=1mA$	-	0.06	-	$V/^\circ\text{C}$
Drain-Source Leakage Current	I_{DSS}	$V_{DS}=60V, V_{GS}=0V,$ $T_J=25^\circ\text{C}$	-	-	1	μA
		$V_{DS}=48V, V_{GS}=0V,$ $T_J=125^\circ\text{C}$	-	-	10	μA
Gate-Source Leakage Current	I_{GSS}	$V_{GS}=\pm 20V, V_{DS}=0V$	-	-	± 100	nA
Static Drain-Source On-Resistance	$R_{DS(ON)}$	$V_{GS}=10V, I_D=4A$	-	24	30	m Ω
		$V_{GS}=4.5V, I_D=3A$	-	29	38	
Gate Threshold Voltage	$V_{GS(th)}$	$V_{GS}=V_{DS}, I_D=250\mu A$	1.2	1.7	2.5	V
$V_{GS(th)}$ Temperature Coefficient	$\Delta V_{GS(th)}$		-	-4.6	-	mV/ $^\circ\text{C}$
Forward Transconductance	g_{fs}	$V_{DS}=10V, I_D=3A$	-	7	-	S
Dynamic and Switching Characteristics						
Total Gate Charge ^{4,5}	Q_g	$V_{DS}=30V, I_D=4A$ $V_{GS}=10V$	-	16.6	24	nC
Gate-Source Charge ^{4,5}	Q_{gs}		-	2.2	4.4	
Gate-Drain Charge ^{4,5}	Q_{gd}		-	3.9	8	
Turn-On Delay Time ^{4,5}	$t_{d(on)}$	$V_{DD}=30V, R_G=6\Omega$ $V_{GS}=10V, I_D=1A$	-	4.6	9	nS
Rise Time ^{4,5}	t_r		-	14.8	28	
Turn-Off Delay Time ^{4,5}	$t_{d(off)}$		-	27.2	52	
Fall Time ^{4,5}	t_f		-	7.8	15	
Input Capacitance	C_{iss}	$V_{DS}=30V, V_{GS}=0V,$ $F=1MHz$	-	1180	1720	pF
Output Capacitance	C_{oss}		-	68	100	
Reverse Transfer Capacitance	C_{rss}		-	45	70	
Gate Resistance	R_g	$V_{GS}=0V, V_{DS}=0V,$ $F=1MHz$	-	2.1	4.2	Ω
Drain-Source Diode Characteristics and Maximum Ratings						
Continuous Source Current	I_S	$V_G=V_D=0V,$ Force Current	-	-	10	A
Pulsed Source Current	I_{SM}		-	-	20	A
Diode Forward Voltage	V_{SD}	$V_{GS}=0V, I_S=1A,$ $T_J=25^\circ\text{C}$	-	-	1	V
Reverse Recovery Time ⁵	t_{rr}	$V_{GS}=0V, I_S=10A$ $di/dt=100A/\mu s$ $T_J=25^\circ\text{C}$	-	23	-	nS
Reverse Recovery Charge ⁵	Q_{rr}		-	13	-	nC

Note:

1. Repetitive rating: Pulsed width limited by maximum junction temperature.
2. $V_{DD}=50V, V_{GS}=10V, L=0.1mH, I_{AS}=23A, R_G=25\Omega,$ starting $T_J=25^\circ\text{C}$.
3. Surface mounted 25.4mm*25.4mm FR-4 board ; 2oz copper pad ; $t \leq 10s$
4. Pulse test: pulse width $\leq 300\mu s,$ duty cycle $\leq 2\%$.
5. Essentially independent of operating temperature.

Typical Electrical and Thermal Characteristic Curves

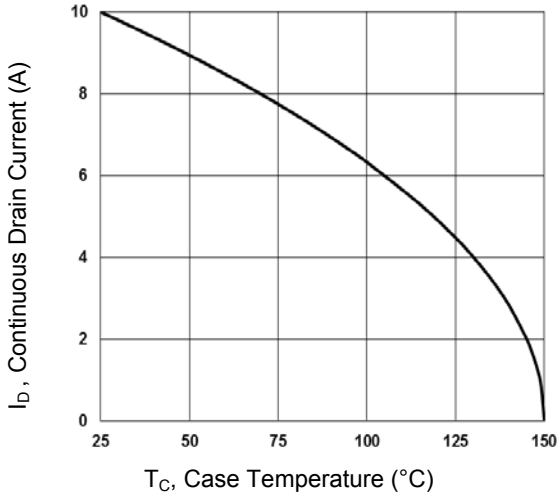

Figure 1. Continuous Drain Current vs. T_c

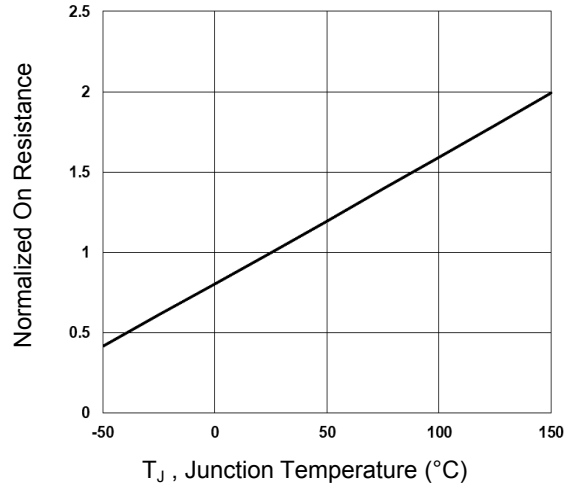

Figure 2. Normalized $R_{DS(ON)}$ vs. T_j

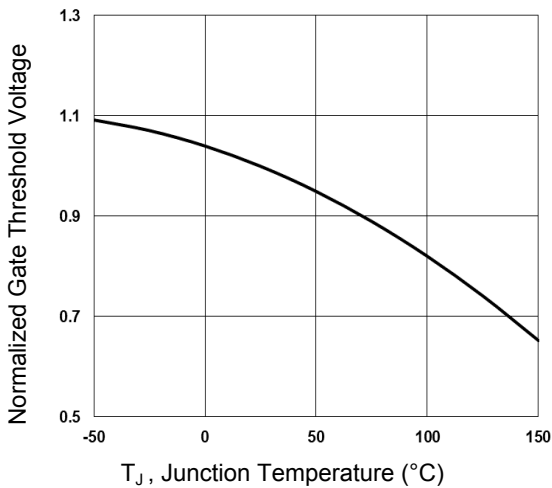

Figure 3. Normalized V_{th} vs. T_j

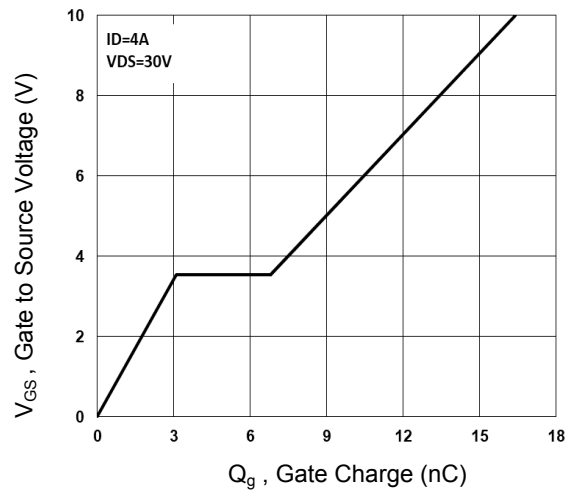

Figure 4. Gate Charge Characteristics

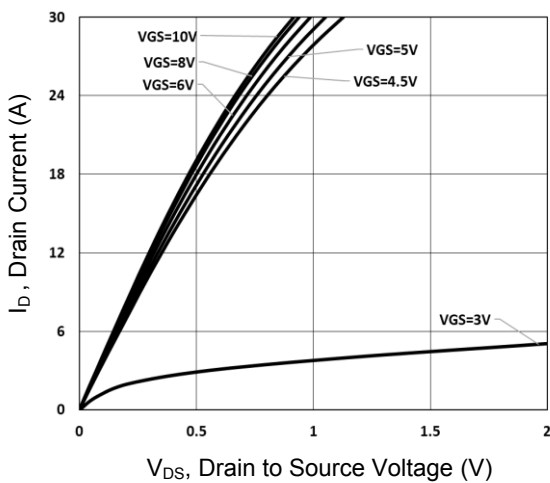

Figure 5. Typical Output Characteristics

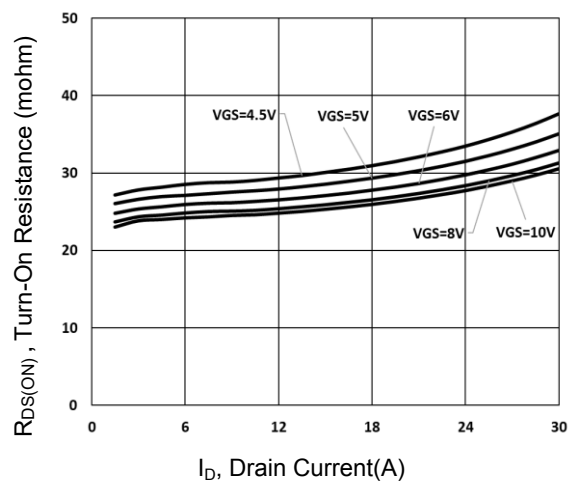

Figure 6. Turn-On Resistance vs. I_D

Typical Electrical and Thermal Characteristic Curves

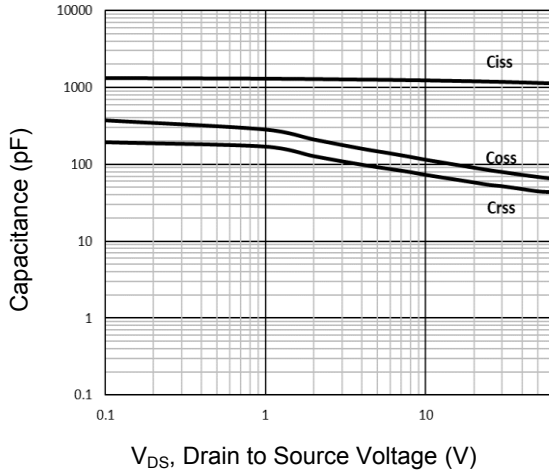

Figure 7. Capacitance Characteristics

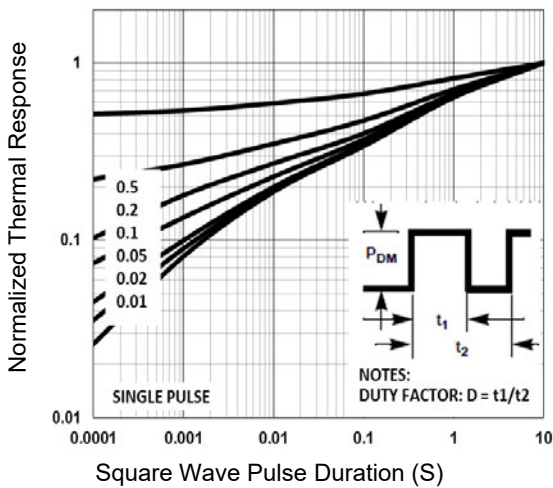

Figure 8. Normalized Transient Impedance

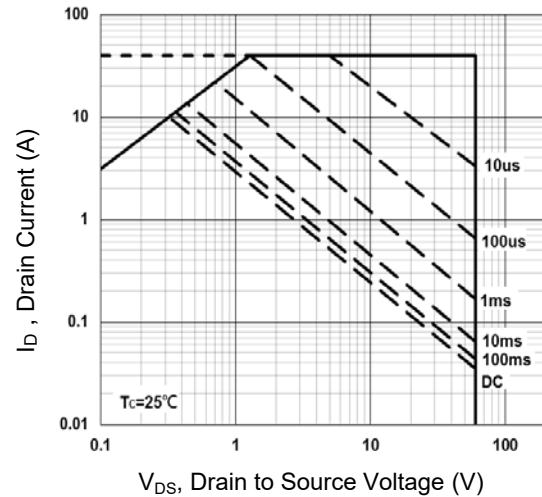

Figure 9. Maximum Safe Operation Area

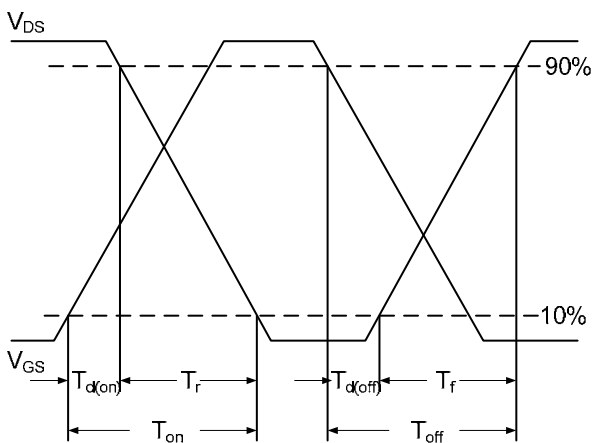

Figure 10. Switching Time Waveform

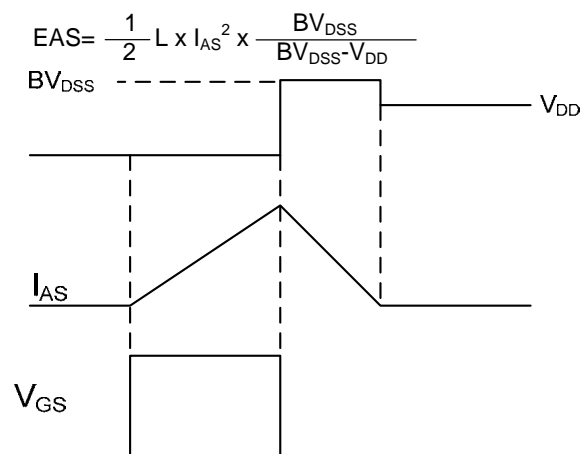
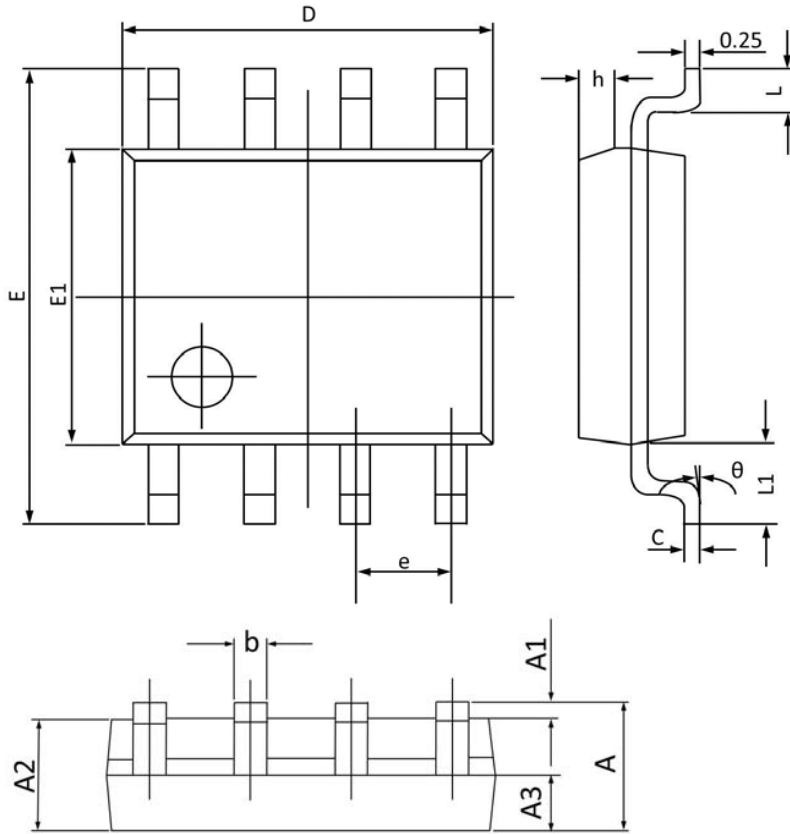

Figure 11. E_{AS} Waveform

Package Outline Dimensions

SOP-8



Symbol	Dimensions In Millimeters		Dimensions In Inches	
	Min	Max	Min	Max
A	1.350	1.800	0.053	0.069
A1	0.050	0.250	0.002	0.010
A2	1.250	1.650	0.049	0.065
A3	0.500	0.700	0.020	0.028
b	0.300	0.510	0.012	0.020
c	0.150	0.260	0.006	0.010
D	4.700	5.100	0.185	0.201
E	5.800	6.200	0.228	0.244
E1	3.700	4.100	0.146	0.161
e	1.270(BSC)		0.050(BSC)	
h	0.250	0.500	0.010	0.020
L	0.400	1.000	0.016	0.039
L1	1.050(BSC)		0.041(BSC)	
θ	0°	8°	0°	8°