

Main Product Characteristics

$V_{(BR)DSS}$	600V
$R_{DS(ON)}$	0.88Ω (Max.)
I_D	5A

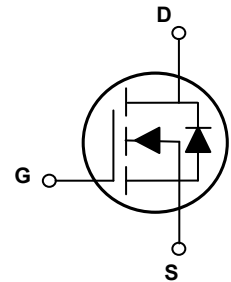

TO-251



Schematic Diagram

Features and Benefits

- Advanced MOSFET process technology
- Ideal for high efficiency switched mode power supplies
- Low on-resistance with low gate charge
- Fast switching and reverse body recovery



Description

The GSJG60R880 utilizes the latest techniques to achieve high cell density and low on-resistance. These features make this device extremely efficient and reliable for use in high efficiency switch mode power supplies and a wide variety of other applications.

Absolute Maximum Ratings (T_C=25°C unless otherwise specified)

Parameter	Symbol	Value	Unit
Drain-Source Voltage	V _{DS}	600	V
Gate-to-Source Voltage	V _{GS}	±30	V
Continuous Drain Current, @ Steady-State (T _C =25°C)	I _D	5	A
Continuous Drain Current, @ Steady-State (T _C =100°C)		3.3	A
Pulsed Drain Current	I _{DM}	20	A
Power Dissipation (T _C =25°C)	P _D	42	W
		0.33	W/°C
Single Pulse Avalanche Energy ¹	E _{AS}	214	mJ
Body Diode Reverse Voltage Slope ²	dv/dt	50	V/ns
MOS dv/dt Ruggedness ³	dv/dt	100	V/ns
Junction-to-Ambient (PCB Mounted, Steady-State)	R _{θJA}	62.0	°C/W
Thermal Resistance, Junction-to-Case	R _{θJC}	2.98	°C/W
Operating Junction and Storage Temperature Range	T _J /T _{STG}	-55 to +150	°C

Electrical Characteristics ($T_C=25^\circ\text{C}$ unless otherwise specified)

Parameter	Symbol	Conditions	Min.	Typ.	Max.	Unit
On / Off Characteristics						
Drain-to-Source Breakdown Voltage	$V_{(BR)DSS}$	$V_{GS}=0V, I_D=250\mu A$	600	-	-	V
Drain-to-Source Leakage Current	I_{DSS}	$V_{DS}=600V, V_{GS}=0V$	-	-	200	nA
Gate-to-Source Forward Leakage	I_{GSS}	$V_{DS}=0V, V_{GS}=30V$	-	-	100	nA
		$V_{DS}=0V, V_{GS}=-30V$	-	-	-100	
Static Drain-to-Source On-Resistance	$R_{DS(ON)}$	$V_{GS}=10V, I_D=2.5A, T_J=25^\circ\text{C}$	-	0.7	0.88	Ω
		$V_{GS}=10V, I_D=2.5A, T_J=125^\circ\text{C}$	-	1.4	-	Ω
Gate Threshold Voltage	$V_{GS(th)}$	$V_{DS}=V_{GS}, I_D=250\mu A$	2.0	-	4.0	V
Dynamic and Switching Characteristics						
Input Capacitance	C_{iss}	$V_{GS}=0V, V_{DS}=100V, f=1\text{MHz}$	-	304	-	pF
Output Capacitance	C_{oss}		-	20	-	
Reverse Transfer Capacitance	C_{rss}		-	1.8	-	
Total Gate Charge ^{4,5}	Q_g	$I_D=5A, V_{DD}=480V, V_{GS}=10V$	-	12	-	nC
Gate-to-Source Charge ^{4,5}	Q_{gs}		-	2.7	-	
Gate-to-Drain ("Miller") Charge ^{4,5}	Q_{gd}		-	6.3	-	
Turn-On Delay Time ^{4,5}	$t_{d(on)}$	$V_{DD}=300V, V_{GS}=10V, R_G=25\Omega, I_D=5A$	-	9	-	nS
Rise Time ^{4,5}	t_r		-	16	-	
Turn-Off Delay Time ^{4,5}	$t_{d(off)}$		-	32	-	
Fall Time ^{4,5}	t_f		-	24	-	
Gate Resistance	R_g	$f=1\text{MHz}$	-	3.6	-	Ω
Source-Drain Ratings and Characteristics						
Continuous Source Current (Body Diode)	I_S	$T_C=25^\circ\text{C}$, MOSFET symbol showing the integral reverse p-n junction diode.	-	-	5	A
Source Pulse Current	I_{SM}		-	-	20	A
Diode Forward Voltage	V_{SD}	$I_S=5A, V_{GS}=0V$	-	-	1.4	V
Reverse Recovery Time ³	T_{rr}	$I_F=5A, V_{GS}=0V, di_F/dt=100A/\mu s$	-	320	-	nS
Reverse Recovery Charge ³	Q_{rr}		-	1.9	-	μC

Note:

1. $L=79\text{mH}$, $I_{AS}=2.2\text{A}$, $V_{DD}=100\text{V}$, starting temperature $T_J=25^\circ\text{C}$.
2. $V_{DS}=0-400\text{V}$, $I_{SD} \leq 20\text{A}$, $T_J=25^\circ\text{C}$.
3. $V_{DS}=0-480\text{V}$.
4. Pulse test: Pulse width $\leq 300\mu\text{s}$, duty cycle $\leq 2\%$.
5. Essentially independent of operating temperature.

Typical Electrical and Thermal Characteristic Curves

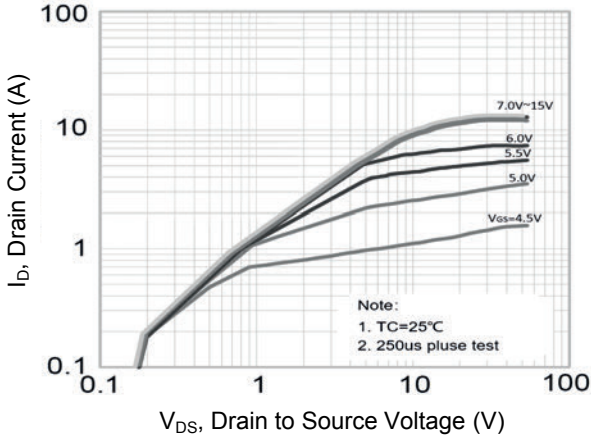

Figure 1. Typical Output Characteristics

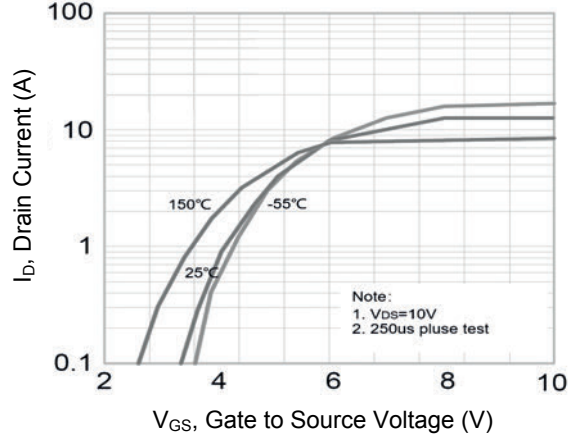

Figure 2. Transfer Characteristics

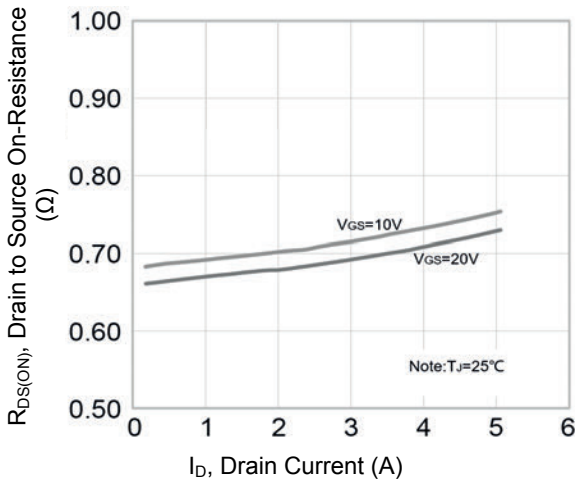

Figure 3. $R_{DS(ON)}$ vs. Drain Current

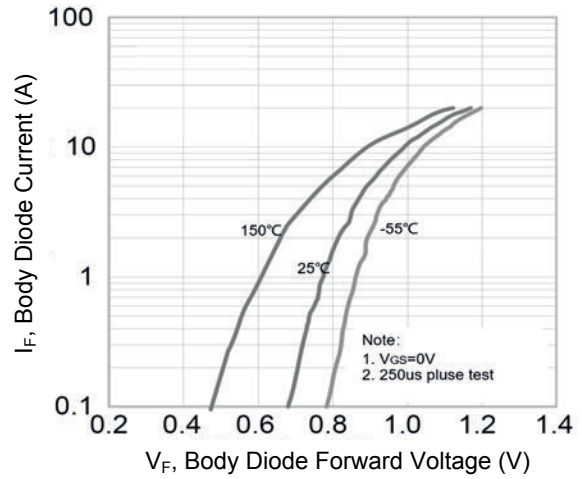

Figure 4. Body Diode Characteristics

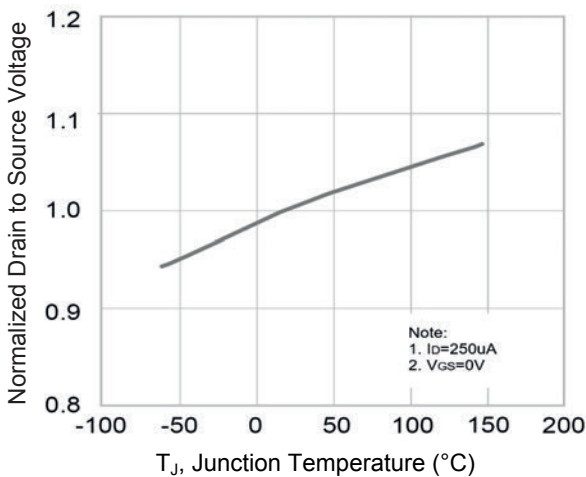

Figure 5. Normalized BV_{DSS} vs. T_J

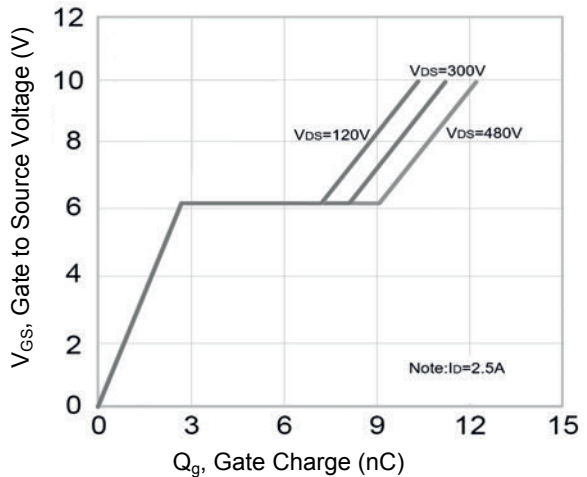

Figure 6. Gate Charge

Typical Electrical and Thermal Characteristic Curves

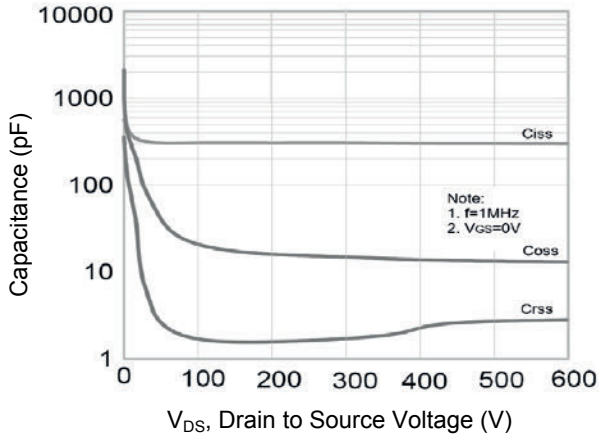

Figure 7. Capacitance Characteristics

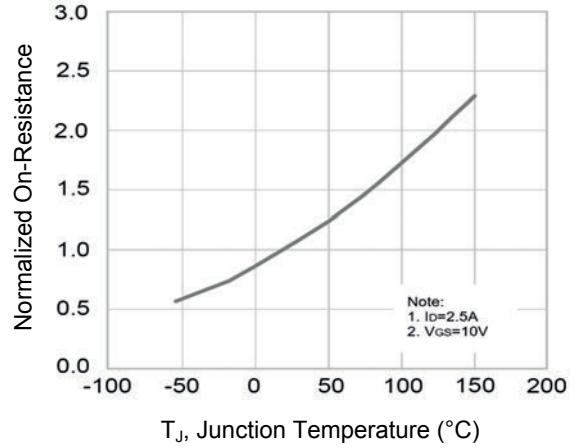

Figure 8. Normalized $R_{DS(ON)}$ vs. T_J

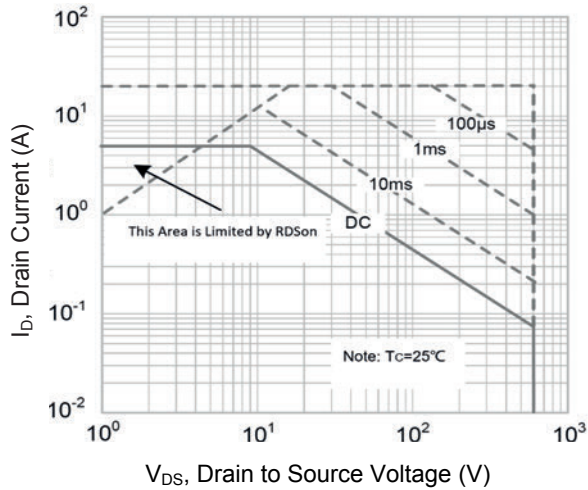
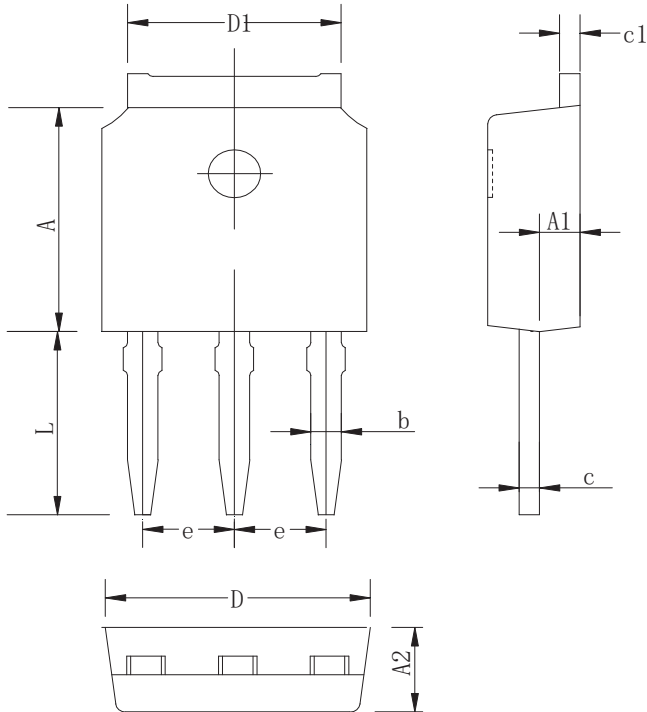

Figure 9. Safe Operation Area

Package Outline Dimensions (TO-251)



Symbol	Dimensions In Millimeters		Dimensions In Inches	
	Min.	Max.	Min.	Max.
A	6.90	7.15	0.272	0.281
A1	0.91	1.11	0.036	0.044
A2	2.20	2.40	0.087	0.094
b	0.66	0.86	0.026	0.034
c	0.46	0.58	0.018	0.023
c1	0.46	0.58	0.018	0.023
D	6.50	6.70	0.256	0.264
D1	5.10	5.46	0.201	0.215
e	0.90	1.05	0.035	0.041
L	4.80	5.20	0.189	0.205

Order Information

Device	Package	Marking	Carrier	Quantity
GSJG60R880	TO-251	G60R880	Tube	80 Pcs / Tube

For more information, please contact us at: inquiry@goodarksemi.com