

Main Product Characteristics

$V_{(BR)DSS}$	650V
$R_{DS(ON)}$	41mΩ (max.)
I_D	70A

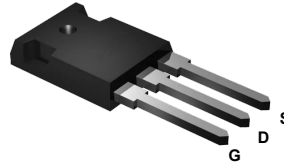

TO-247

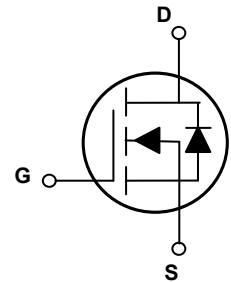

Schematic Diagram

Features and Benefits

- Advance MOSFET process technology
- Ideal for high efficiency switched mode power supplies
- Low on-resistance with low gate charge
- Fast switching and reverse body recovery



Description

The GSJA65R041 utilizes the latest techniques to achieve high cell density and low on-resistance. These features make this device extremely efficient and reliable for use in high efficiency switch mode power supplies and a wide variety of other applications.

Absolute Maximum Ratings ($T_J=25^\circ\text{C}$ unless otherwise specified)

Parameter	Symbol	Max.	Unit
Drain-Source Voltage	V_{DS}	650	V
Gate-Source Voltage	V_{GS}	± 30	V
Drain Current-Continuous, at Steady-State, ($T_C=25^\circ\text{C}$)	I_D	70	A
Drain Current-Continuous, at Steady-State, ($T_C=100^\circ\text{C}$)		46	
Drain Current-Pulsed	I_{DM}	260	A
Single Pulse Avalanche Energy ¹	E_{AS}	2768	mJ
Power Dissipation ($T_C=25^\circ\text{C}$)	P_D	500	W
		4.0	W/°C
Body Diode Reverse Voltage Slope ²	dv/dt	50	V/ns
MOS dv/dt Ruggedness ³	dv/dt	100	V/ns
Junction-to-Ambient (PCB Mounted, Steady-State)	$R_{\theta JA}$	50	°C/W
Thermal Resistance, Junction-to-Case	$R_{\theta JC}$	0.25	°C/W
Operating Junction Temperature Range	T_J	-55 To +150	°C
Storage Temperature Range	T_{STG}	-55 To +150	°C
Soldering Temperature	T_{SOLD}	260	°C

Electrical Characteristics (T_J=25°C unless otherwise specified)

Parameter	Symbol	Conditions	Min.	Typ.	Max.	Unit
On / Off Characteristics						
Drain-Source Breakdown Voltage	BV _{DSS}	V _{GS} =0V, I _D =250uA	650	-	-	V
Drain-Source Leakage Current	I _{DSS}	V _{DS} =650V, V _{GS} =0V, T _J =25°C	-	-	6	μA
		V _{DS} =650V, V _{GS} =0V, T _J =125°C	-	80	-	μA
Gate-Source Leakage Current	I _{GSS}	V _{GS} =±30V, V _{DS} =0V	-	-	±100	nA
Static Drain-Source On-Resistance	R _{DS(ON)}	V _{GS} =10V, I _D =35A	-	37	41	mΩ
Gate Threshold Voltage	V _{GS(th)}	V _{GS} =V _{DS} , I _D =250uA	3.0	-	5.0	V
Dynamic and Switching Characteristics						
Total Gate Charge ^{4,5}	Q _g	V _{DD} =480V, I _D =50A, V _{GS} =10V	-	326	-	nC
Gate-Source Charge ^{4,5}	Q _{gs}		-	47	-	
Gate-Drain ("Miller") Charge ^{4,5}	Q _{gd}		-	210	-	
Gate to Plateau ^{4,5}	V _{plateau}		-	6.6	-	V
Turn-On Delay Time ^{4,5}	t _{d(on)}	V _{DD} =400V, R _G =1.8Ω, V _{GS} =13V, I _D =50A	-	36	-	nS
Rise Time ^{4,5}	t _r		-	52	-	
Turn-Off Delay Time ^{4,5}	t _{d(off)}		-	208	-	
Fall Time ^{4,5}	t _f		-	47	-	
Input Capacitance	C _{iss}	V _{DS} =100V, V _{GS} =0V, F=1MHz	-	7132	-	pF
Output Capacitance	C _{oss}		-	284	-	
Reverse Transfer Capacitance	C _{rss}		-	5.7	-	
Gate Resistance	R _g	F=1MHz	-	1.4	-	Ω
Drain-Source Diode Characteristics and Maximum Ratings						
Continuous Source Current (Body Diode)	I _S	T _C =25°C, MOSFET symbol showing the integral reverse p-n junction diode.	-	-	70	A
Pulsed Source Current	I _{SM}		-	-	360	A
Diode Forward Voltage	V _{SD}	V _{GS} =0V, I _S =50A	-	-	1.4	V
Reverse Recovery Time ⁴	t _{rr}	V _{GS} =0V, I _S =50A, di/dt=100A/μs	-	173	-	nS
Reverse Recovery Charge ⁴	Q _{rr}		-	1.2	-	μC
Reverse Recovery Peak Current ⁴	I _{rrm}		-	11	-	A

Note:

- L=79mH, I_{AS}=7.8A, V_{DD}=100V, R_G=25Ω, starting temperature T_J=25°C.
- V_{DS}= 0 - 400V, I_{SD} ≤ I_S, T_J=25°C.
- V_{DS}= 0 - 400V.
- Pulse test: pulse width ≤ 300us, duty cycle ≤ 2%.
- Essentially independent of operating temperature.

Typical Electrical and Thermal Characteristic Curves

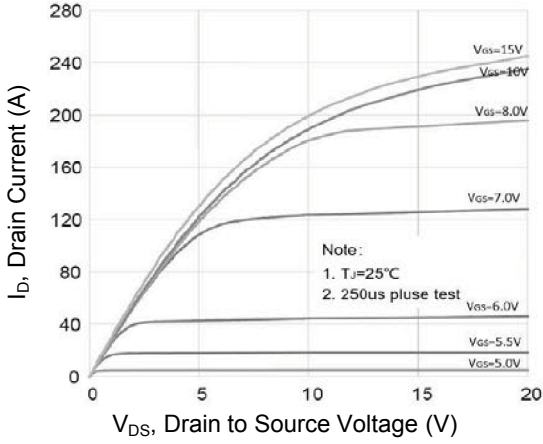

Figure 1. Typical Output Characteristics

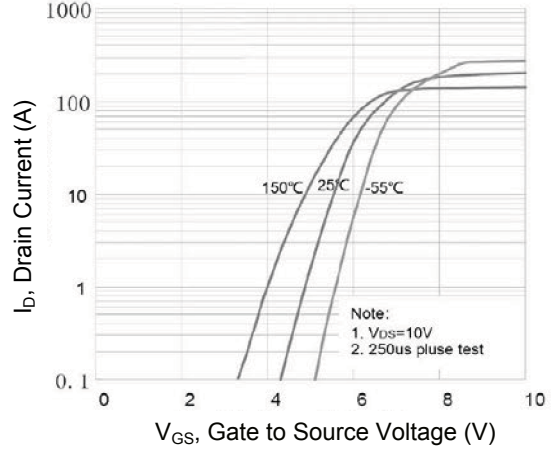

Figure 2. Transfer Characteristics

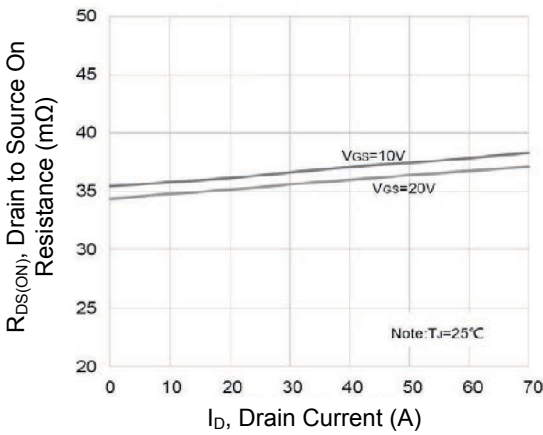

Figure 3. $R_{DS(ON)}$ vs. Drain Current

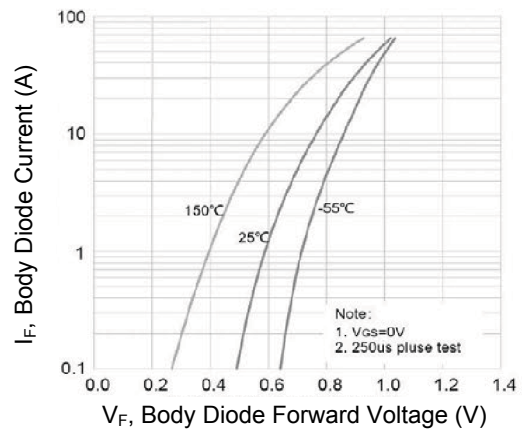

Figure 4. Body Diode Characteristics

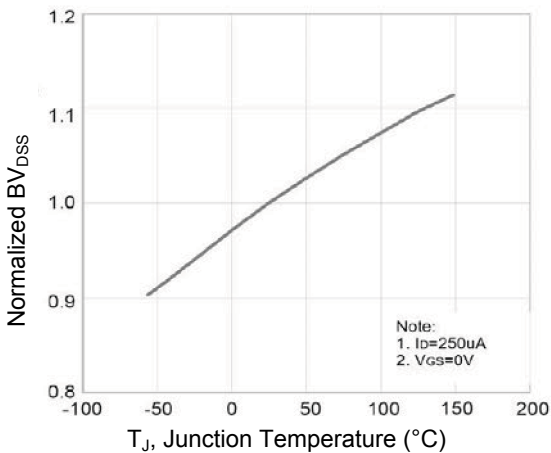

Figure 5. Normalized BV_{DSS} vs. T_J

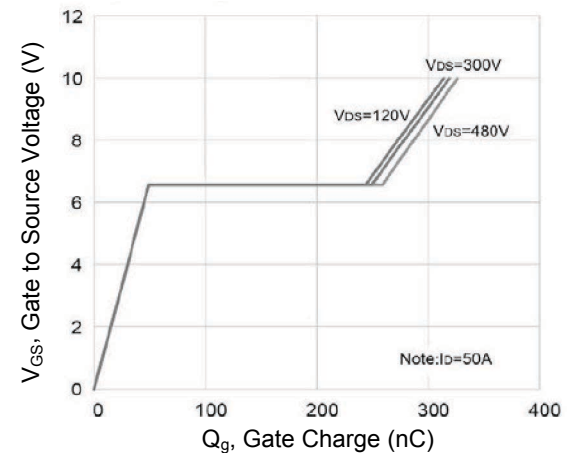

Figure 6. Gate Charge Characteristics

Typical Electrical and Thermal Characteristic Curves

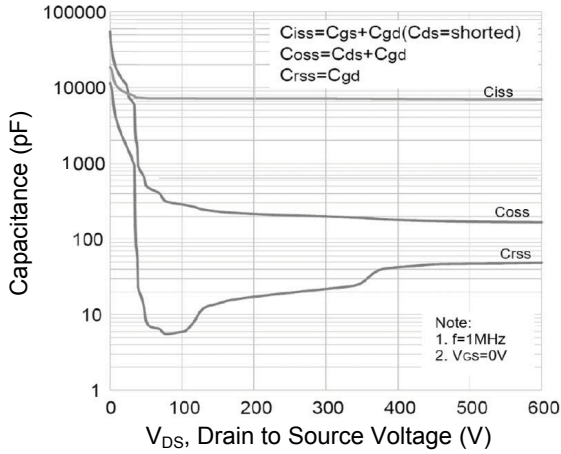

Figure 7. Capacitance Characteristics

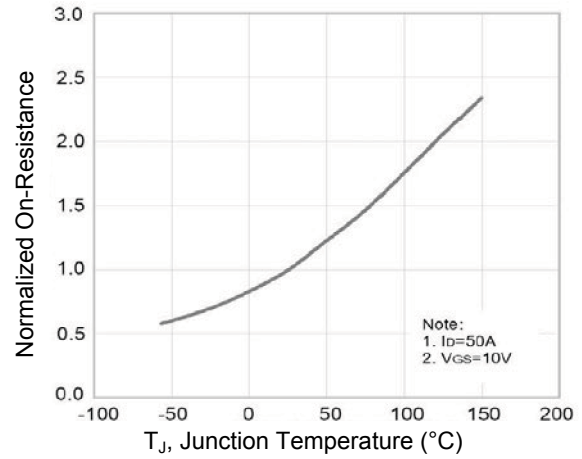

Figure 8. Normalized $R_{DS(ON)}$ vs. T_J

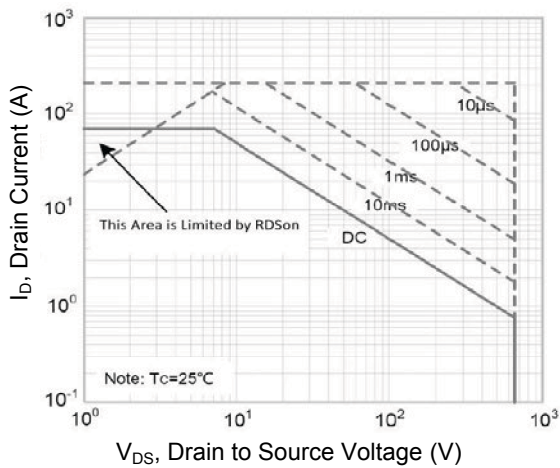
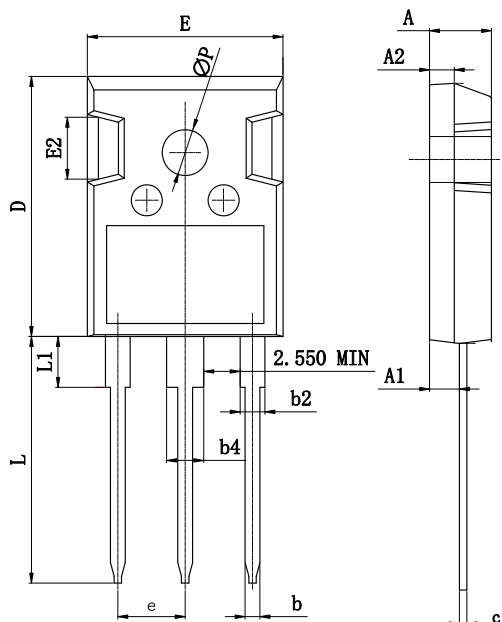

Figure 9. Safe Operation Area

Package Outline Dimensions (TO-247)



Symbol	Dimensions In Millimeters		Dimensions In Inches	
	Min.	Max.	Min.	Max.
A	4.75	5.20	0.187	0.205
A1	2.21	2.65	0.087	0.104
A2	1.85	2.15	0.073	0.085
b	1.00	1.36	0.039	0.054
b2	1.80	2.25	0.071	0.089
b4	2.91	3.25	0.115	0.128
c	0.51	0.75	0.020	0.030
D	20.80	21.30	0.819	0.839
E	15.50	16.10	0.610	0.634
E2	4.40	5.20	0.173	0.205
e	5.44 BSC		0.214 BSC	
L	19.72	20.22	0.776	0.796
L1	-	4.30	-	0.169
P	3.40	3.80	0.134	0.150

Order Information

Device	Package	Marking	Carrier	Quantity
GSJA65R041	TO-247	A65R041	Tube	30pcs / Tube

For more information, please contact us at: inquiry@goodarksemi.com