

Main Product Characteristics

$V_{(BR)DSS}$	600V
$R_{DS(ON)}$	33mΩ (max.)
I_D	83A

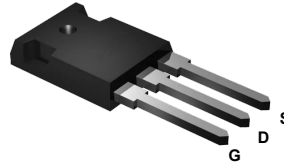

TO-247

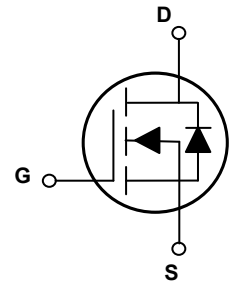

Schematic Diagram

Features and Benefits

- Advanced MOSFET process technology
- Ideal for high efficiency switched mode power supplies
- Low on-resistance with low gate charge
- Fast switching and reverse body recovery



Description

The GSJA60R032 utilizes the latest techniques to achieve high cell density and low on-resistance. These features make this device extremely efficient and reliable for use in high efficiency switch mode power supplies and a wide variety of other applications.

Absolute Maximum Ratings (T_J=25°C unless otherwise specified)

Parameter	Symbol	Parameter	Unit
Drain-Source Voltage	V _{DS}	600	V
Gate-to-Source Voltage	V _{GS}	±20	V
Continuous Drain Current, @ Steady-State (T _C =25°C)	I _D	83	A
Continuous Drain Current, @ Steady-State (T _C =100°C)		52	A
Pulsed Drain Current	I _{DM}	249	A
Power Dissipation (T _C =25°C)	P _D	544	W
		4.35	W/°C
Single Pulse Avalanche Energy ¹	E _{AS}	3228	mJ
Body Diode Reverse Voltage Slope ²	dv/dt	50	V/ns
MOS dv/dt Ruggedness ³	dv/dt	50	V/ns
Junction-to-Ambient (PCB Mounted, Steady-State)	R _{θJA}	50	°C/W
Junction-to-Case	R _{θJC}	0.23	°C/W
Operating Junction and Storage Temperature Range	T _J /T _{STG}	-55 to +150	°C
Soldering Temperature	T _{sold}	260	°C

Electrical Characteristics ($T_J=25^\circ\text{C}$ unless otherwise specified)

Parameter	Symbol	Conditions	Min.	Typ.	Max.	Unit
On / Off Characteristics						
Drain-to-Source Breakdown Voltage	$V_{(BR)DSS}$	$V_{GS}=0V, I_D=250\mu A$	600	-	-	V
Drain-to-Source Leakage Current	I_{DSS}	$V_{DS}=600V, V_{GS}=0V, T_J=25^\circ\text{C}$	-	-	1.0	μA
		$V_{DS}=600V, V_{GS}=0V, T_J=125^\circ\text{C}$	-	23	-	μA
Gate-to-Source Forward Leakage	I_{GSS}	$V_{DS}=0V, V_{GS}=20V$	-	-	100	nA
		$V_{DS}=0V, V_{GS}=-20V$	-	-	-100	
Static Drain-to-Source On-Resistance	$R_{DS(ON)}$	$V_{GS}=10V, I_D=35A$	-	28.5	33	m Ω
Gate Threshold Voltage	$V_{GS(th)}$	$V_{DS}=V_{GS}, I_D=250\mu A$	3.0	-	5.0	V
Dynamic and Switching Characteristics						
Input Capacitance	C_{iss}	$V_{GS}=0V, V_{DS}=200V, f=1\text{MHz}$	-	7700	-	pF
Output Capacitance	C_{oss}		-	227	-	
Reverse Transfer Capacitance	C_{rss}		-	10	-	
Total Gate Charge ^{4,5}	Q_g	$I_D=42A, V_{DD}=480V, V_{GS}=10V$	-	169	-	nC
Gate-to-Source Charge ^{4,5}	Q_{gs}		-	61	-	
Gate-to-Drain ("Miller") Charge ^{4,5}	Q_{gd}		-	71	-	
Gate Plateau ^{4,5}	$V_{plateau}$		-	7.5	-	V
Turn-On Delay Time ^{4,5}	$t_{d(on)}$	$V_{DD}=400V, V_{GS}=10V, R_G=4.7\Omega, I_D=42A$	-	60	-	nS
Rise Time ^{4,5}	t_r		-	74	-	
Turn-Off Delay Time ^{4,5}	$t_{d(off)}$		-	134	-	
Fall Time ^{4,5}	t_f		-	43	-	
Gate Resistance	R_g	$f=1\text{MHz}$	-	2.0	-	Ω
Source-Drain Ratings and Characteristics						
Continuous Source Current (Body Diode)	I_S	$T_C=25^\circ\text{C}$, MOSFET symbol showing the integral reverse p-n junction diode.	-	-	83	A
Source Pulse Current	$I_{S, pulse}$		-	-	249	A
Diode Forward Voltage	V_{SD}	$I_S=42A, V_{GS}=0V$	-	-	1.4	V
Reverse Recovery Time ⁴	T_{rr}	$I_S=42A, V_{GS}=0V, V_R=400V, di_F/dt=100A/\mu s$	-	173	-	nS
Reverse Recovery Charge ⁴	Q_{rr}		-	1.23	-	μC
Reverse Recovery Peak Current ⁴	I_{rrm}		-	14	-	A

Notes:

1. $L=79\text{mH}, I_{AS}=7.8A, V_{DD}=100V, R_G=25\Omega$, starting temperature $T_J=25^\circ\text{C}$.
2. $V_{DS}=0-400V, I_{SD}\leq I_S, T_J=25^\circ\text{C}$.
3. $V_{DS}=0-400V$.
4. Pulse test : pulse width $\leq 300\mu s$, duty cycle $\leq 2\%$.
5. Essentially independent of operating temperature.

Typical Electrical and Thermal Characteristic Curves

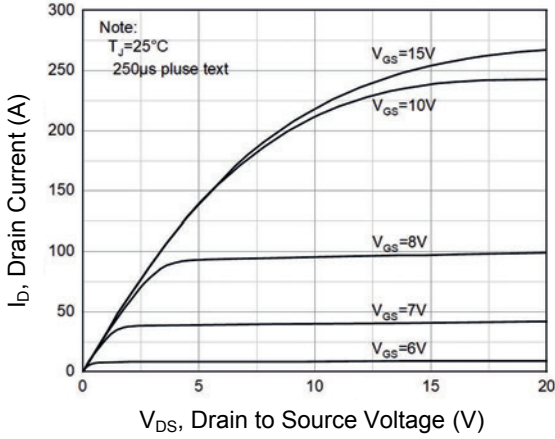

Figure 1. Typical Output Characteristics

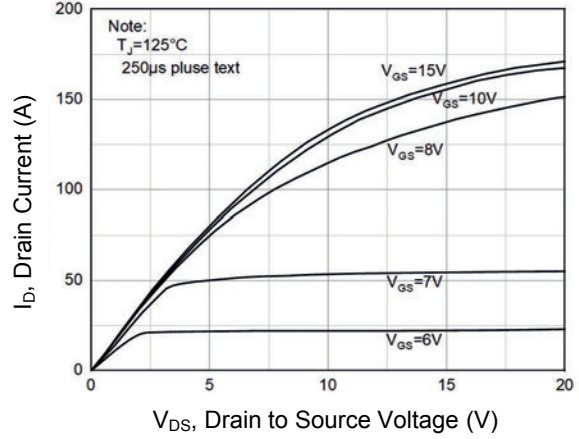

Figure 2. Typical Output Characteristics

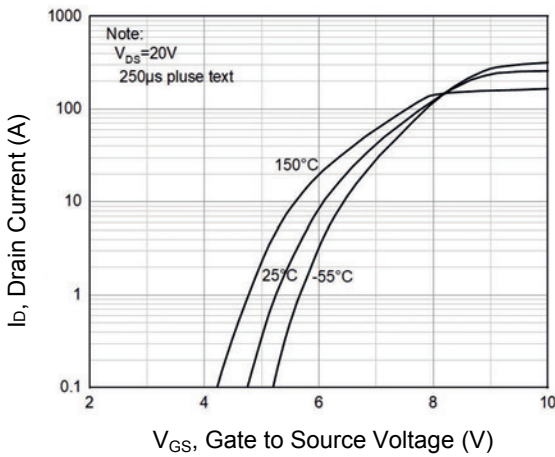

Figure 3. Transfer Characteristics

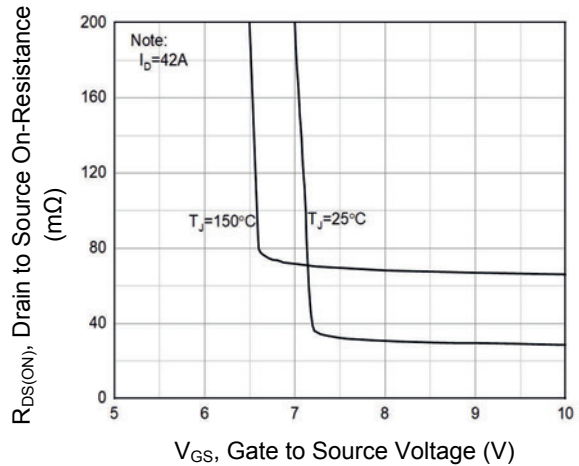

Figure 4. $R_{DS(ON)}$ vs. V_{GS}

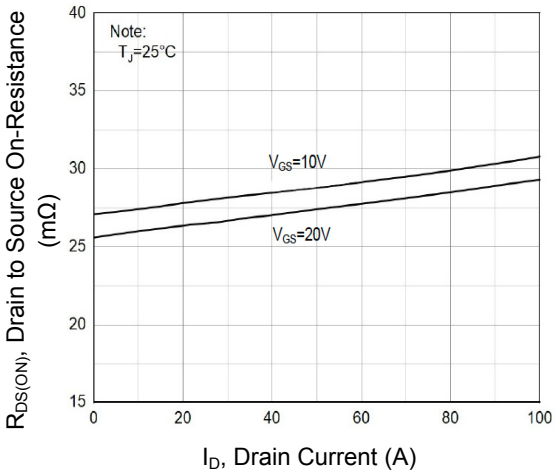

Figure 5. $R_{DS(ON)}$ vs. Drain Current

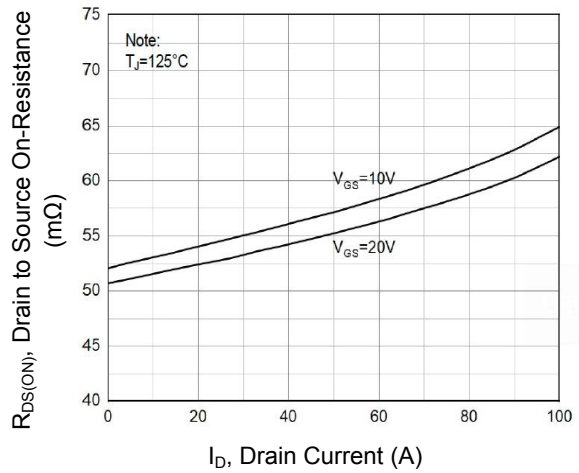

Figure 6. $R_{DS(ON)}$ vs. Drain Current

Typical Electrical and Thermal Characteristic Curves

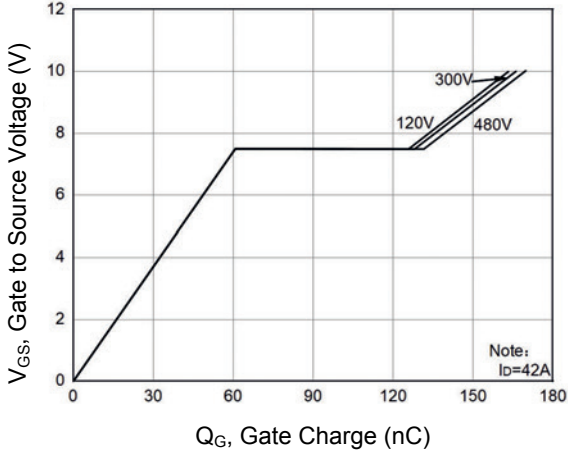

Figure 7. Gate Charge Characteristics

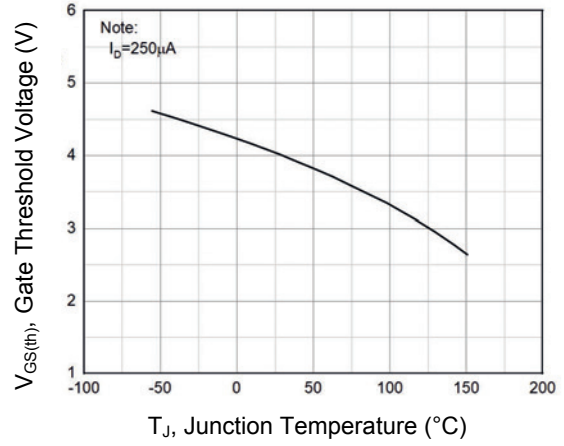

Figure 8. $V_{GS(th)}$ vs. T_J

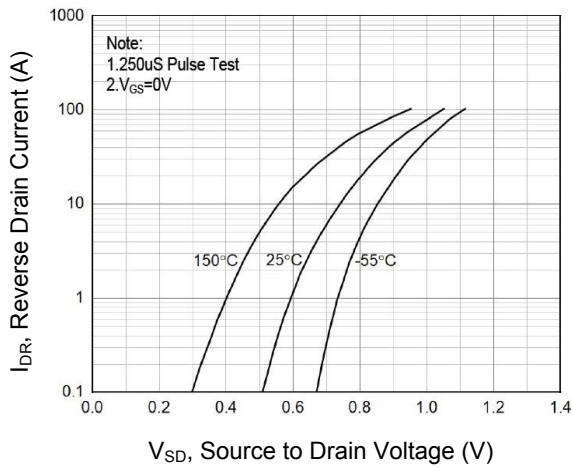

Figure 9. Body Diode Characteristics

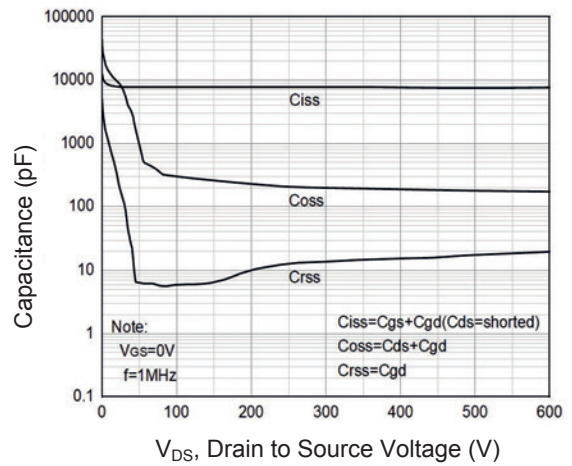

Figure 10. Capacitance Characteristics

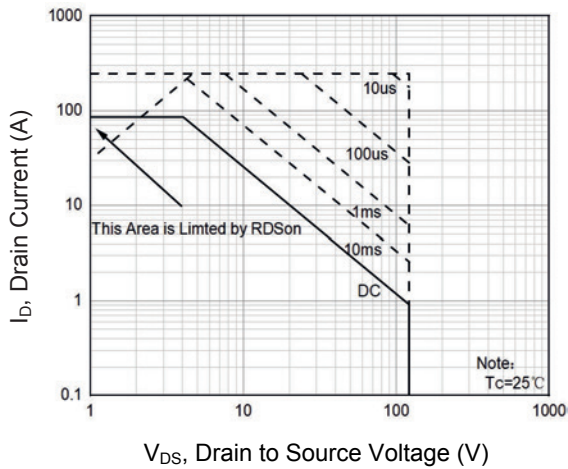

Figure 11. Safe Operation Area

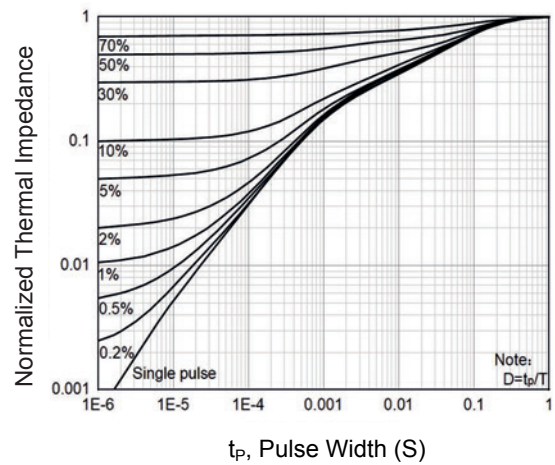
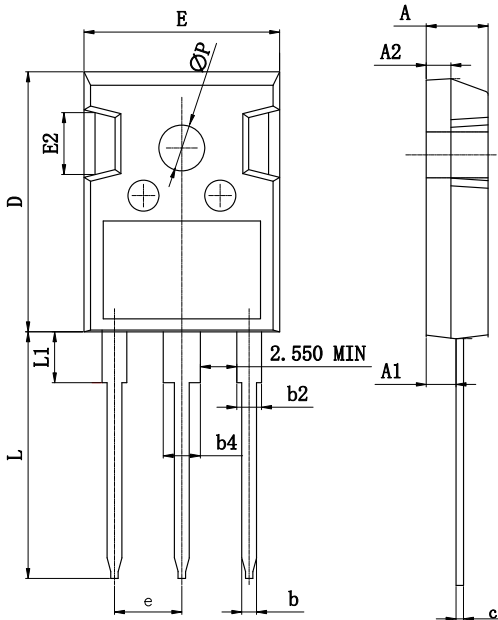

Figure 12. Transient Thermal Impedance vs. t_p

Package Outline Dimensions (TO-247)



Symbol	Dimensions In Millimeters		Dimensions In Inches	
	Min.	Max.	Min.	Max.
A	4.75	5.20	0.187	0.205
A1	2.21	2.65	0.087	0.104
A2	1.85	2.15	0.073	0.085
b	1.00	1.36	0.039	0.054
b2	1.80	2.25	0.071	0.089
b4	2.91	3.25	0.115	0.128
c	0.51	0.75	0.020	0.030
D	20.80	21.30	0.819	0.839
E	15.50	16.10	0.610	0.634
E2	4.40	5.20	0.173	0.205
e	5.44 BSC		0.214 BSC	
L	19.72	20.22	0.776	0.796
L1	-	4.30	-	0.169
P	3.40	3.80	0.134	0.150

Order Information

Device	Package	Marking	Carrier	Quantity
GSJA60R032	TO-247	A60R032	Tube	30pcs / Tube

For more information, please contact us at: inquiry@goodarksemi.com