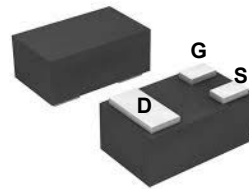
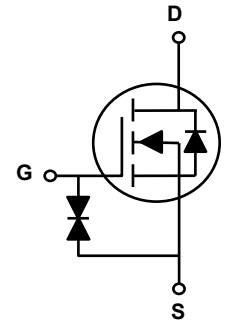


## Main Product Characteristics

$V_{DS}$	20V
$R_{DS(ON)}$	230m $\Omega$
$I_D$	1.4A



SOT-883



Schematic Diagram

## Features and Benefits

- Advanced MOSFET process technology
- Ideal for high efficiency switched mode power supplies
- Low on-resistance with low gate charge
- Fast switching and reverse body recovery



## Description

The GSFW0202 utilizes the latest techniques to achieve high cell density and low on-resistance. These features make this device extremely efficient and reliable for use in high efficiency switch mode power supply and a wide variety of other applications.

## Absolute Maximum Ratings (T<sub>J</sub>=25°C unless otherwise specified)

Parameter	Symbol	Max.	Unit
Drain-Source Voltage	$V_{DSS}$	20	V
Gate-Source Voltage	$V_{GSS}$	±8	V
Drain Current-Continuous <sup>1,3</sup> (T <sub>A</sub> =25°C)	$I_D$	1.4	A
Drain Current-Continuous <sup>1,3</sup> (T <sub>A</sub> =70°C)		1.1	
Drain Current-Pulsed <sup>2</sup>	$I_{DM}$	3.5	A
Diode Continuous Forward Current	$I_S$	0.6	A
Power Dissipation(T <sub>A</sub> =25°C)	$P_D$	0.7	W
Power Dissipation(T <sub>A</sub> =70°C)		0.4	
Thermal Resistance, Junction-to-Ambient <sup>2</sup>	$R_{\theta JA}$	180	°C/W
Storage Temperature Range	T <sub>STG</sub>	-55 To +150	°C
Operating Junction Temperature Range	T <sub>J</sub>	-55 To +150	°C

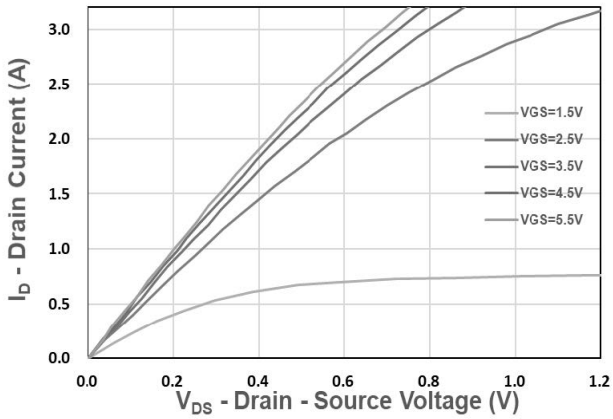
**Electrical Characteristics** ( $T_J=25^{\circ}\text{C}$  unless otherwise specified)

Parameter	Symbol	Conditions	Min.	Typ.	Max.	Unit
Drain-Source Breakdown Voltage	$V_{(BR)DSS}$	$V_{GS}=0V, I_D=250\mu A$	20	-	-	V
Zero Gate Voltage Drain Current	$I_{DSS}$	$V_{DS}=16V, V_{GS}=0V$	-	-	1	$\mu A$
Gate Threshold Voltage	$V_{GS(th)}$	$V_{DS}=V_{GS}, I_{DS}=250\mu A$	0.5	-	1	V
Gate-Source Leakage Current	$I_{GSS}$	$V_{GS}=\pm 8V, V_{DS}=0V$	-	-	$\pm 10$	$\mu A$
Drain-Source On-State Resistance	$R_{DS(on)}$	$V_{GS}=4.5V, I_D=0.55A$	-	190	230	m $\Omega$
		$V_{GS}=2.5V, I_D=0.45A$	-	234	305	
		$V_{GS}=1.8V, I_D=0.35A$	-	303	455	
Forward Transconductance	$g_{fs}$	$V_{DS}=5V, I_D=0.55A$	-	1.7	-	S
Total Gate Charge	$Q_g$	$V_{DS}=10V, I_D=1A,$ $V_{GS}=2.5V$	-	1.1	-	nC
Total Gate Charge	$Q_g$	$V_{DS}=10V, I_D=1A,$ $V_{GS}=4.5V$	-	2	-	nC
Gate-Source Charge	$Q_{gs}$		-	0.3	-	
Gate-Drain Charge	$Q_{gd}$		-	0.3	-	
Turn-On Delay Time	$t_{d(on)}$	$V_{DS}=10V, R_{GEN}=6\Omega,$ $V_{GS}=4.5V, I_D=2A$	-	1.2	-	nS
Turn-On Rise Time	$t_r$		-	25	-	
Turn-Off Delay Time	$t_{d(off)}$		-	14	-	
Turn-Off Fall Time	$t_f$		-	15	-	
Input Capacitance	$C_{iss}$	$V_{DS}=10V, V_{GS}=0V,$ $F=1MHz$	-	43	-	pF
Output Capacitance	$C_{oss}$		-	9	-	
Reverse Transfer Capacitance	$C_{rss}$		-	6	-	
<b>Reverse Diode Characteristics</b>						
Diode Forward Voltage	$V_{SD}$	$V_{GS}=0V, I_{SD}=0.35A$	-	-	1.1	V
Reverse Recovery Time	$t_{rr}$	$I_F=1A,$ $di/dt=100A/\mu s$	-	9	-	nS
Reverse Recovery Charge	$Q_{rr}$		-	1	-	nC

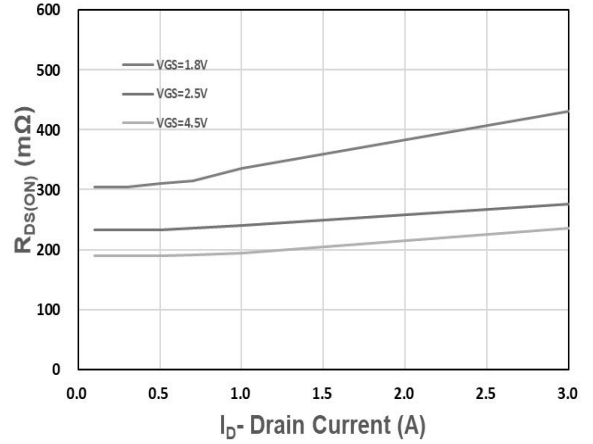
Note :

1. The value of  $R_{\theta JA}$  is measured with the device mounted on 1in2 FR-4 board with 2oz. Copper, in a still air environment with  $T_A=25^{\circ}\text{C}$ . The value in any given application depends on the user's specific board design.
2. Repetitive rating, pulse width limited by junction temperature .
3. The current rating is based on the  $t < 10s$  junction to ambient thermal resistance rating.

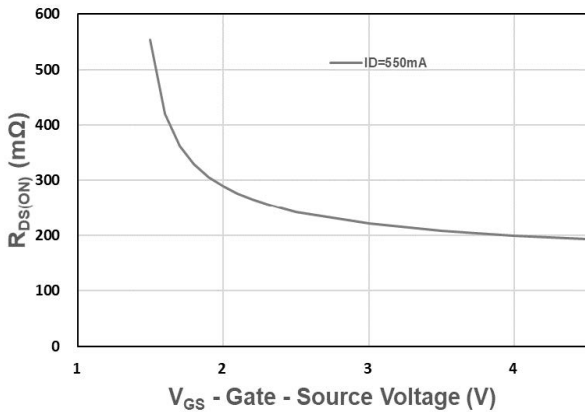
**Typical Electrical and Thermal Characteristic Curves**



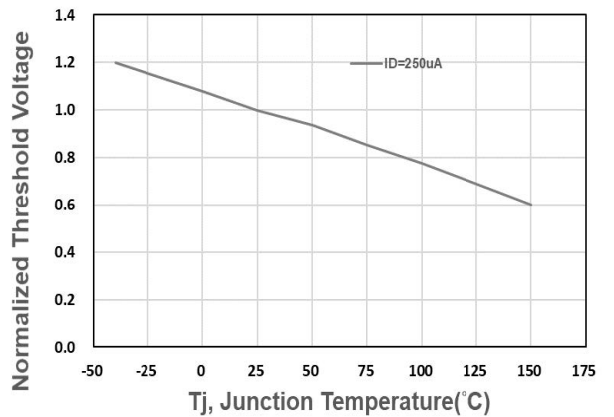
**Figure 1. Output Characteristics**



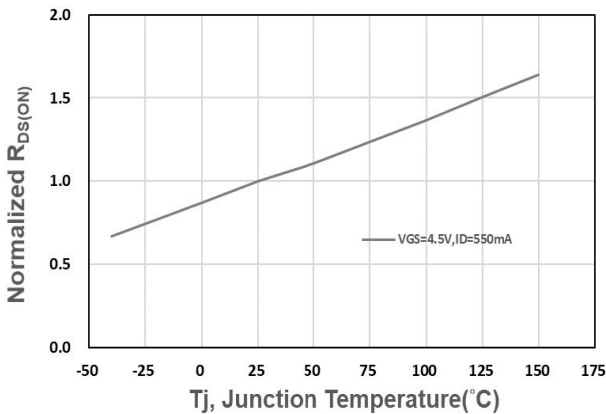
**Figure 2. On-Resistance vs.  $I_D$**



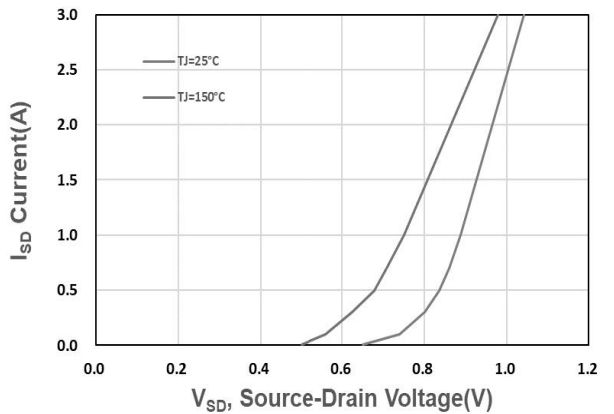
**Figure 3. On-Resistance vs.  $V_{GS}$**



**Figure 4. Gate Threshold Voltage**

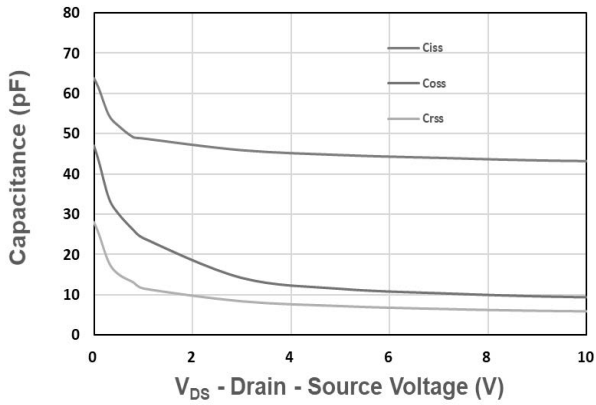


**Figure 5. Drain-Source On Resistance**

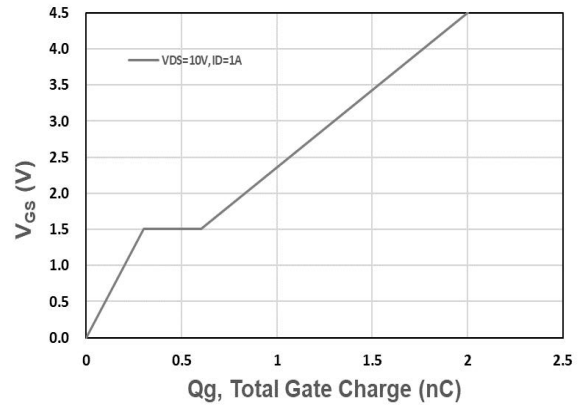


**Figure 6. Source-Drain Diode Forward**

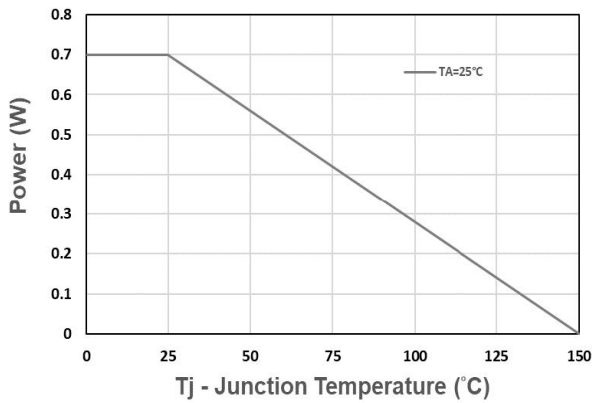
**Typical Electrical and Thermal Characteristic Curves**



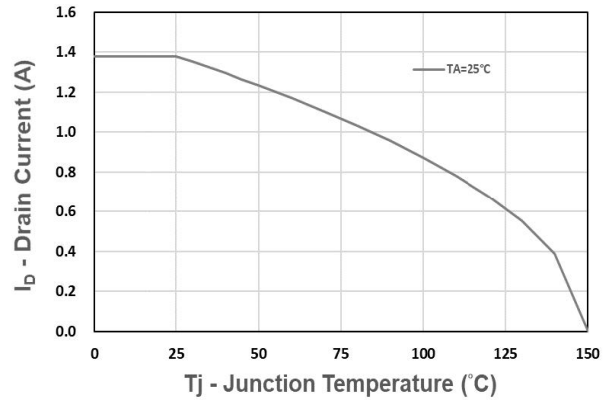
**Figure 7. Capacitance**



**Figure 8. Gate Charge Characteristics**

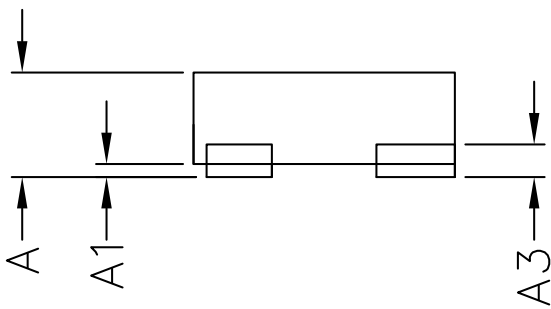
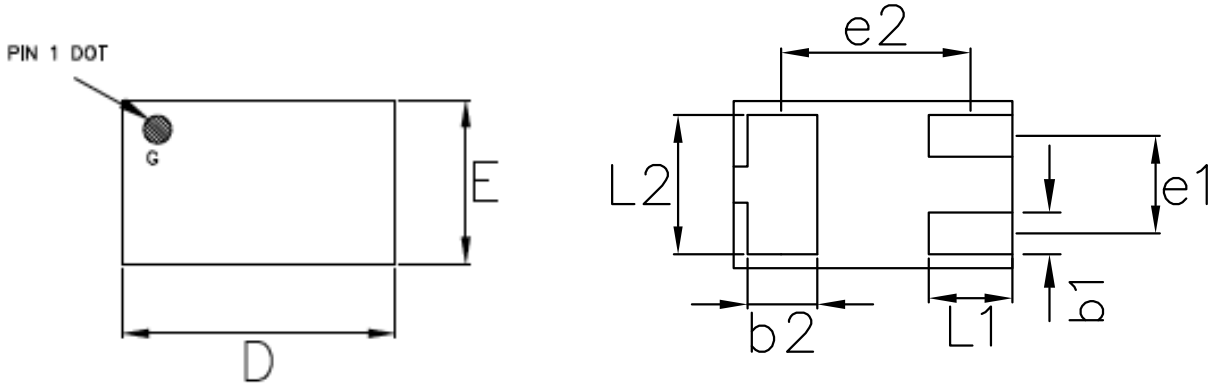


**Figure 9. Power Dissipation**



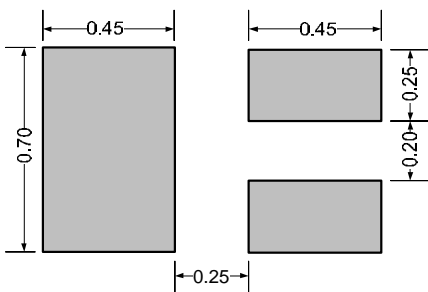
**Figure 10. Drain Current**

## Package Outline Dimensions (SOT-883)



Package Outline Dimensions (MM)			
Package	SOT-883		
REF.	MIN.	TYP.	MAX
A	0.40	-	0.50
A1	0.001	-	0.05
A3	0.125 REF.		
D	0.95	1.00	1.05
E	0.55	0.60	0.65
b1	0.10	0.15	0.20
b2	0.20	0.25	0.30
L1	0.20	0.30	0.40
L2	0.40	0.50	0.60
e1	0.35 BSC		
e2	0.675 BSC		

## Recommended Pad Layout



(Unit in MM)

## Order Information

MPN	Package	Marking Code	Carrier	Quantity	HSF Status
GSFW0202	SOT-883	48	Tape & Reel	10,000/Reel	RoHS Compliant

For more information, please contact us at: [inquiry@goodarksemi.com](mailto:inquiry@goodarksemi.com)